

10-5-2017

Real-Time Energy Price-Aware Anycast RWA for Scheduled Lightpath Demands in Optical Data Center Networks

Karan Neginhal
University of Windsor

Follow this and additional works at: <https://scholar.uwindsor.ca/etd>

Recommended Citation

Neginhal, Karan, "Real-Time Energy Price-Aware Anycast RWA for Scheduled Lightpath Demands in Optical Data Center Networks" (2017). *Electronic Theses and Dissertations*. 7284.
<https://scholar.uwindsor.ca/etd/7284>

This online database contains the full-text of PhD dissertations and Masters' theses of University of Windsor students from 1954 forward. These documents are made available for personal study and research purposes only, in accordance with the Canadian Copyright Act and the Creative Commons license—CC BY-NC-ND (Attribution, Non-Commercial, No Derivative Works). Under this license, works must always be attributed to the copyright holder (original author), cannot be used for any commercial purposes, and may not be altered. Any other use would require the permission of the copyright holder. Students may inquire about withdrawing their dissertation and/or thesis from this database. For additional inquiries, please contact the repository administrator via email (scholarship@uwindsor.ca) or by telephone at 519-253-3000ext. 3208.

**Real-Time Energy Price-Aware Anycast RWA for Scheduled
Lightpath Demands in Optical Data Center Networks**

By

Karan Neginhal

A Thesis

Submitted to the Faculty of Graduate Studies
through the School of Computer Science
in Partial Fulfillment of the Requirements for

The Degree of Master of Science at the University of Windsor

Windsor, Ontario, Canada

2017

© 2017 Karan Neginhal

**Real-Time Energy Price-Aware Anycast RWA for Scheduled Lightpath
Demands in Optical Data Center Networks**

by

Karan Neginhal

APPROVED BY:

A. Sarker
Department of Mathematics and Statistics

S. Mavromoustakos
School of Computer Science

A. Jaekel, Advisor
School of Computer Science

September 19, 2017

DECLARATION OF ORIGINALITY

I hereby certify that I am the sole author of this thesis and that no part of this thesis has been published or submitted for publication.

I certify that, to the best of my knowledge, my thesis does not infringe upon anyone's copyright nor violate any proprietary rights and that any ideas, techniques, quotations, or any other material from the work of other people included in my thesis, published or otherwise, are fully acknowledged in accordance with the standard referencing practices. Furthermore, to the extent that I have included copyrighted material that surpasses the bounds of fair dealing within the meaning of the Canada Copyright Act, I certify that I have obtained a written permission from the copyright owner(s) to include such material(s) in my thesis and have included copies of such copyright clearances to my appendix.

I declare that this is a true copy of my thesis, including any final revisions, as approved by my thesis committee and the Graduate Studies office, and that this thesis has not been submitted for a higher degree to any other University or Institution.

ABSTRACT

The energy consumption of the data center networks and the power consumption associated with transporting data to the users is considerably large, and it constitutes a significant portion of their costs. Hence, development of energy efficient schemes is very crucial to address this problem. Our research considers the fixed window traffic allocation model and the anycast routing scheme to select the best option for the destination node. Proper routing schemes and appropriate combination of the replicas can take care of the issue for energy utilization and at the same time help diminish costs for the data centers. We have also considered the real-time pricing model (which considers price changes every hour) to select routes for the lightpaths. Hence, we propose an ILP to handle the energy-aware routing and wavelength assignment (RWA) problem for fixed window scheduled traffic model, with an objective to minimize the overall electricity costs of a datacenter network by reducing the actual power consumption, and using low-cost resources whenever possible.

DEDICATION

*Dedicated to my parents Vijay Neginhal and Bharti Neginhal
and also my friends in the School of Computer Science.*

ACKNOWLEDGEMENTS

I take this as an opportunity to express my sincere gratitude to my advisor, Dr. Arunita Jaekel, for her valuable guidance during my research. This work could not have been accomplished without her continuous support, advice and encouragement. I would like to thank my thesis committee members Dr. Stephanos Mavromoustakos and Dr. Animesh Sarker for their professional assistance and valuable time.

I would also like to thank Saja Al Mamoori, Karen Bourdeau and the entire computer science faculty members for all the support they provided throughout my years of study. I would like to express my deepest gratitude to my family for being a source of motivation and strength.

Karan Neginhal

TABLE OF CONTENTS

DECLARATION OF ORIGINALITY	iii
ABSTRACT.....	iv
DEDICATION	v
ACKNOWLEDGEMENTS	vi
LIST OF TABLES	ix
LIST OF FIGURES	x
LIST OF ABBREVIATIONS/SYMBOLS	xii
CHAPTER 1 INTRODUCTION	1
1.1 Overview.....	1
1.1.1 Wavelength Division Multiplexing Networks.....	1
1.2 Motivation.....	3
1.3 Problem Statement & Solution Outline.....	4
1.4 Thesis Organization.....	5
CHAPTER 2 REVIEW.....	7
2.1 Optical Networks.....	7
2.2 Data Transmission.....	9
2.3 Wavelength Division Multiplexing.....	9
2.4 Routing and Wavelength Assignment.....	11
2.4.1 Energy Aware Routing Wavelength Assignment.....	12
2.5 Anycast Routing.....	13
2.6 Traffic Demand Allocation Models.....	14
2.7 Datacenter.....	16
2.8 Lightpath.....	18
2.9 Physical and Logical Topology.....	19
2.10 Literature Review.....	20

2.11 Summary of Literature Review	27
CHAPTER-3 ENERGY EFFICIENT ANYCAST ROUTING FOR FIXED WINDOW SCHEDULED TRAFFIC MODEL.....	28
3.1 Introduction.....	28
3.2 Network Energy Model.....	28
3.3 Solution Approach.....	30
3.4 Proposed ILP.....	30
3.4.1 Justification of the ILP.....	34
3.5 Some Alternative Objective Functions.....	36
3.5.1 Objective Function 2 (Minimize Hops).....	36
3.5.2 Objective Function 3 (Minimize Distance).....	37
3.5.3 Objective Function 4 (Minimize Energy).....	37
3.6 An Illustrative Example.....	38
CHAPTER-4 EXPERIMENTATION AND RESULTS.....	42
4.1 Simulation Parameters.....	42
4.2 Comparison of experimental results.....	45
4.2.1 Comparison of different network topologies.....	45
4.2.2 Comparison of different demand sizes.....	49
4.2.3 Comparison of prices for Objective 4 (real time vs flat rate).....	52
4.2.4 Comparison with different replicas.....	53
4.2.5 Comparison with different channels.....	55
CHAPTER -5 CONCLUSION AND FUTURE WORK.....	56
5.1 Conclusion.....	56
5.2 Future work.....	57
REFERENCES/BIBLIOGRAPHY.....	59
VITA AUCTORIS	65

LIST OF TABLES

Table 2.1	Literature Review Summary	27
Table 3.1	Power Consumption of network devices	29
Table 3.2	Minimized values for Objectives	40
Table 4.1	Minimized values for Objective 1 (40 Demands)	46
Table 4.2	Minimized values for Objective 2 (40 Demands)	46
Table 4.3	Minimized values for Objective 3 (40 Demands)	47
Table 4.4	Minimized values for Objective 4 (40 Demands)	47
Table 4.5	Minimized values for Objective 1 (14 – node topology)	49
Table 4.6	Minimized values for Objective 2 (14 – node topology)	50
Table 4.7	Minimized values for Objective 3 (14 – node topology)	50
Table 4.8	Minimized values for Objective 4 (14 – node topology)	51
Table 4.9	Values for Objective 4 with Real time and Flat rate prices for 40 demands	53
Table 4.10	Values for Objective 4 with Real time and Flat rate prices for 14-node	53
Table 4.11	Values for Objective 4 with 4 - replicas, 3 – replicas and 2 - replicas (14 - node)	54
Table 4.12	Values for different Objectives with 16 - channels and 4 - channels (11 - node)	55

LIST OF FIGURES

Figure 2.1	Optical Cable	7
Figure 2.2	Layers in an Optical Fiber	8
Figure 2.3	Total internal reflection inside Optical Fiber	9
Figure 2.4	Wavelength Division Multiplexing (WDM)	10
Figure 2.5	Routing Wavelength Assignment (RWA)	12
Figure 2.6	Anycast routing	13
Figure 2.7	Logical Topology and traffic routing	14
Figure 2.8	Fixed window demand allocation model	15
Figure 2.9	Demand scheduling under the sliding window model	16
Figure 2.10	Datacenter	17
Figure 2.11	Nodes representing datacenters in a network	17
Figure 2.12	Lightpath setup in a 5-node network	19
Figure 2.13	Physical Topology	19
Figure 2.14	Logical Topology	20
Figure 3.1	A sample physical topology	38
Figure 3.1	A sample set of lightpath requests	38
Figure 3.2	Routing of lightpath demands for Objective 1	40
Figure 3.3	Routing of lightpath demands for Objective 2	41
Figure 3.4	Routing of lightpath demands for Objective 3	41

Figure 3.5	Routing of lightpath demands for Objective 4	41
Figure 4.1	Topology 11-node network: 24 links	43
Figure 4.2	Topology 14-node network: 21 links	44
Figure 4.3	Topology 24-node network: 43 links	44
Figure 4.4	Cost Values with different Objectives for different topologies (40 Demands)	48
Figure 4.5	Cost Values with different Objectives for different demands (14 - Node)	52
Figure 4.6	Dollar Cost Values with different replicas for different demands (14 - Node)	54

LIST OF ABBREVIATIONS/SYMBOLS

DC – Data Center

WDM – Wavelength Division Multiplexing

RWA – Routing and Wavelength Assignment

RTP – Real Time Pricing

ILP - Integer Linear Program

LAN – Local Area Network

MAN – Metropolitan Area Network

WAN – Wide Area Network

SLE – Static Lightpath Establishment

DLE – Dynamic Lightpath Establishment

DCN – Data Center Networks

TNDP – Two Node Disjoint Path

OTN – Optical Transport Network

SLR – Single Line Rate

MLR – Mixed Line Rate

DCI – Data Center Interconnect

EON – Elastic Optical Networking

EA-RWA – Energy Aware Routing Wavelength Assignment

LP – Lightpath

OEO – Optical-Electrical-Optical

MUX - Multiplexer

DEMUX – Demultiplexer

OXC – Optical Cross Connect

COST-239 – European network topology

NSFNET – National Science Network

DWDM - Dense Wavelength Division Multiplexing

IDE – Integrated Development Environment

CHAPTER 1

INTRODUCTION

1.1 Overview

Web services such as e-mail, web search and video storage have become an essential part of life. Data centers contain a network's most fundamental systems and are essential to the continuity of daily operations. "A Datacenter (DC) can be pictured as a server that is utilized for storage, computing resources and circulation of the substantial measure of information [2]." "With the fast rise of large-scale benefit applications, and rapidly growing distributed computing and capacity, the number and size of data centers have increased extensively [1]." As a result of the increase in the number of data centers, the power consumption has also increased rapidly. Power utility cost is a noteworthy operating expense of DCNs [3]. Data centers and communication networks around the world consume about 500 to 750 TWh combined annually [4], which has been increasing with growing cloud computing. "A little development in energy management can save hundreds of million dollars of electricity cost [1]"

1.1.1 Wavelength Division Multiplexing Networks

The innovation of utilizing various optical signals on a similar fiber is called wavelength division multiplexing (WDM). WDM innovation has been enhancing consistently as of late, with existing frameworks fit for giving huge measures of data transmission on a single fiber link. Wavelength Division Multiplexing (WDM) in optical networks has made it conceivable to plan large communication networks with high throughput.

Lightpath

A *lightpath* is an optical connection from one end node to another [8]. It starts from an end node, bridges a number of fibers and router nodes, and terminates in another end node [2]. Lightpaths are used to carry data in the form of optical signals. Several lightpaths can be transmitted on a single fiber using different carrier wavelengths. One of the challenges involved in designing wavelength routed networks is to develop efficient algorithms for establishing lightpaths in the optical network [7]. The algorithms must be able to select routes and assign wavelengths to connections in a manner which efficiently utilizes network resources (channels/wavelengths) [2].

Routing and Wavelength Assignment (RWA)

The problem of assigning resources to lightpaths in WDM networks is defined as the *Routing and Wavelength Assignment (RWA)*. The RWA problems are considered as the NP-complete problems [8]. The main objective of the RWA problem is to establish as many lightpaths as possible, considering the resource limitations which minimizes the network operation cost and increases the network performance [6].

In numerous applications, the actual location of the server remains hidden from the user as it is not vital. In this case, it is possible to select the best destination from the set of possible destinations to execute a job. This phenomenon is known as anycasting. Anycast routing explicitly enables users to transmit data for processing and service delivery, without assigning an specific destination [9].

There are fundamentally three different demand allocations models for WDM optical networks. In static traffic model, the set of demands is fixed and known in advance.

For dynamic traffic, the setup time and the duration of the demands are not known in advance; they are generated based on certain distributions [39]. Scheduled traffic model is predictable and periodic in nature. In scheduled traffic demands the setup time and the teardown time for the demand are known in advance. The scheduled traffic model is categorized into two different models, known as fixed window traffic model and sliding scheduled traffic model.

1.2 Motivation

Data Centers have become one of the fastest growing consumers of electricity due to the explosion of digital content, big data, e-commerce and Internet traffic [10]. To support high availability and bandwidth, data center networks are designed based on peak traffic, but peak traffic does not happen all the time [3]. This leads to unnecessary energy wastage and low network utilization [3]. The power consumption inside the data center is the most vital component, but it is also very essential to consider the power consumption associated with carrying data between data centers and end users [13][39]. The growing energy requirements have resulted in a 25% step-up in the annual energy costs over the past few years [12].

These figures indicate that high energy consumption by the data centers can become a bottleneck as it leads to higher costs economically and affects the environment. The development of energy efficient schemes is very crucial at all levels of network infrastructure to address this problem. Efficient routing schemes and proper combination of the replicas can solve the problem for energy consumption and concurrently help reduce costs for the data centers. Replication makes it possible to have indistinguishable duplicates

of data on different servers and over more than one data center. In the recent years, some research works have been published in the field of energy-aware data center networks. Some different routing approaches such as Shortest Hop Path (SHP) and Shortest Distance Path (SDP) has been proposed based on the concept of replication [1]. SDP tries to find the routes with minimal fiber distance between user and replica. SHP finds routes with a minimum number of intermediate nodes between user and replica [1]

There are fluctuating power costs everyday and furthermore all through a given day [1]. One pricing model that takes these fluctuations into account is real-time pricing (RTP). RTP helps reduce costs for the customers and also helps in increasing the efficiency on the retailer side. There are a growing number of researchers who use RTP to optimize the electricity cost [1]. The Least Dollar Path (LDP) approach in [1] considers the real-time energy costs and replicated data storage to avoid costly peak charges and reduce the overall energy cost [1]. Although this algorithm has received significant attention in recent years and has also produced great results, the idea of implementing it for different traffic models such as the scheduled traffic has not been studied yet.

1.3 Problem Statement & Solution Outline

The energy consumption of data center networks is considerably large and constitutes a significant portion of their operating costs [3]. In this research work, we aim to minimize the overall electricity costs of a data center network by reducing the actual power consumption, and using low-cost resources whenever possible. We have considered the fixed window traffic allocation model and the anycast routing scheme to select the best

option for the destination node. We have also considered the real-time pricing model to select routes for the lightpaths.

Several researches show that routing schemes can affect the overall energy consumption of a network [19] - [24]. Rather than using the traditional *unicast* routing, our proposed approach uses the *anycast* principle to select the most suitable destination for a given demand [39]. We have developed a new integer linear program (ILP) formulation to solve this energy-aware routing problem. We consider power consumption at both network nodes (e.g., in IP routers, optical switches) and along fiber links. Considering the real-time energy pricing, we try to minimize the electricity costs and plan to achieve greater savings.

To obtain the optimal solution for our problem, we model the problem as an *Integer Linear Programming* (ILP) and solve the ILP with a widely used solver, CPLEX (IBM ILOG, 2012) [46]. We consider the scheduled traffic model for our problem. To evaluate the performance of our ILP, we check the solutions generated by the ILP on different standard topologies like NSFNET, COST-239. We have performed simulations on different network topologies, different demand sets and traffic loads [2]. The results demonstrate that our proposed approach can lead to significant reductions in dollar costs.

1.4 Thesis Organization

The rest of this thesis is organized as follows: Chapter 2 provides a review of some of the concepts and terminologies that are related to this work and seeks to provide more details of the areas related to this research. It also includes a review of some of the closely related work of other researchers. In Chapter 3, we define the problem and present the proposed algorithm. Chapter 4 discusses the simulation results of our experimentation and

analysis of our obtained results. In Chapter 5, we conclude the thesis by proposing some future work.

CHAPTER 2

REVIEW

2.1 Optical Networks

An optical network connects computers (or some other gadget which can produce or store data in electronic form) using optical fibers. Optical network can be worked over a wide variety of networks like LAN (Local Area Network), MAN (Metropolitan Area Network) and WAN (Wide Area Network). It uses optical fiber links as the essential communication medium for transforming data and moving data in the form of optical signals between sender and receiver nodes [14]. Optical fibers are very thin glass cylinders or filaments which carry signals in the form of light (optical signals) [2][14]. They are arranged in bundles, known as optical cables and are utilized to transmit signals over long distances [14]. Figure 2.1 shows the optical cable with the bundle of several optical fibers [2].

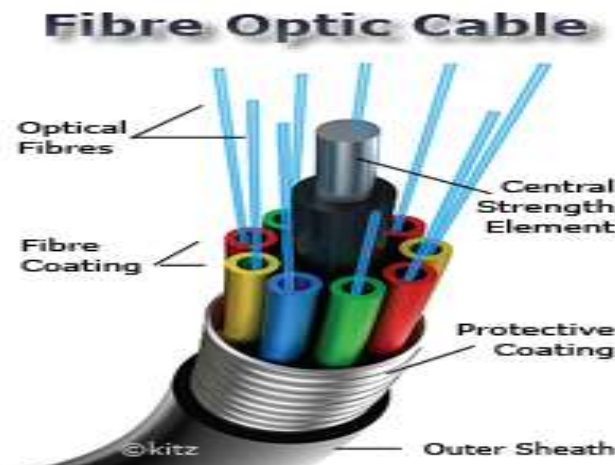

Figure 2.1: Optical Cable [34]

Fiber optic data transmission systems deliver signals through optical fibers by converting electronic signals into light [15]. An optical fiber consists of three layers: core, cladding, and buffer. Cylindrical core is the innermost layer and is made up of a very high-quality glass (silica) or plastic [15-16]. The cladding is the outer material surrounding the core and it is also made of glass [2]. The third layer, i.e., buffer is identified as the external layer of an optical fiber and is composed of plastic such as nylon or acrylic [2]. The refractive index of the core is greater than that of the cladding. A buffer shields the core and cladding from any physical damage. “An optical signal moves through the core in the form of light pulses and bounces into the cladding which reflects the light back to the core [2]”. This phenomenon is known as total internal reflection, and it results in lower light signal attenuation and less energy loss [15]. Fig. 2.2 shows a typical optical fiber and its three layers.

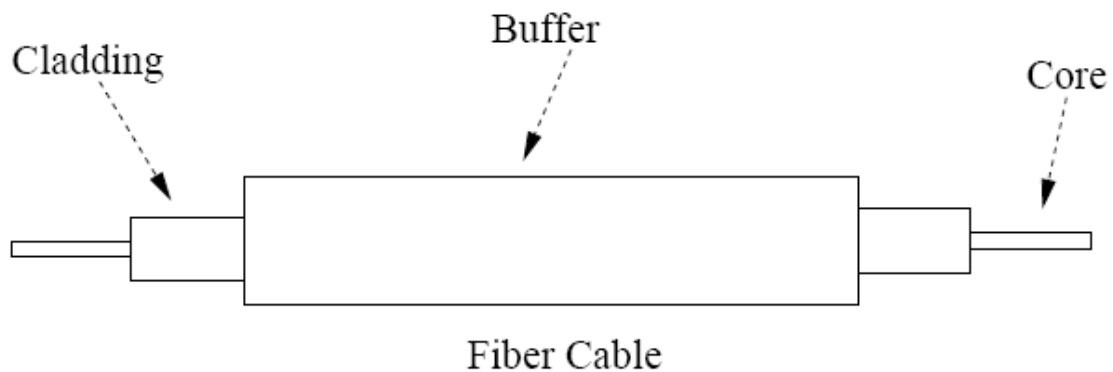

Figure 2.2: Layers of an optical fiber

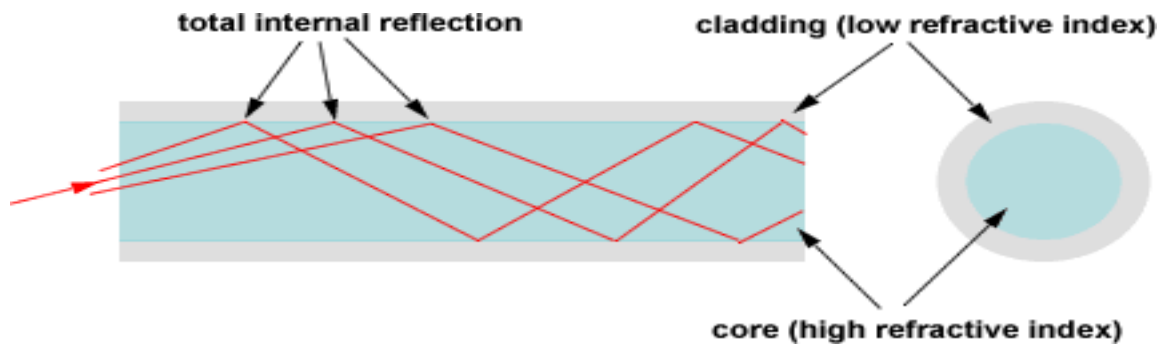

Figure 2.3 Total Internal Reflection inside optical fiber [35]

2.2. Data Transmission

In an optical network, data communication is accomplished by the utilization of transmitters at source and receivers at the destination of the lightpath [8]. The central component of the transmitter is a laser diode that is used to produce a beam of light, and the main element of a receiver is a photodetector which is to identify a beam of light [8]. Modulation is a methodology of converting data in electronic form to encode an optical signal [5]. The main part of the receiver is photodetector or photodiode which transforms an optical signal into an electrical form at the destination at some specific carrier wavelength. It restores or extracts the data into the original form, i.e., is electrical form [5]. Every channel has a corresponding transmitter and receiver pair.

2.3 Wavelength Division Multiplexing

WDM systems are being utilized in telecommunication networks with the optical signals being converted back to electronic signals at each node. These optoelectronic switching and processing costs at the nodes can be very high which affects the performance and also the delivery of optical link bandwidth to the end users [5-6]. Hence to prevent such constrictions we consider the concept of lightpaths in an optical network. There is no

need for optical-electronic conversion at any intermediate node in the route from the source to the destination of the communication.

“Wavelength-division-multiplexing (WDM) technology is currently perceived as one of the key advances in optical communications systems [2]”. This is because it has extraordinary potential to improve system design and flexibility [17]. The entire bandwidth of the optical fiber is divided into the number of channels, and each channel is assigned a specific wavelength. Each channel can be routed independently of each other and can carry many low-speed demands, which leads to better utilization of the bandwidth [39]. WDM networks can carry data on multiple channels by utilizing a single fiber. In WDM networks light from different laser sources, each with a distinct wavelength is blended into single beam with the help of a multiplexer [2]. At the receiving end, a Demultiplexer (DEMUX) is placed that separates the wavelengths from the beam into independent optical signals. The transmitter contains a laser and a modulator. The light source produces an optical carrier signal at either fixed or tunable wavelength [2]. The receiver is composed of a photodiode detector which converts an optical signal into an electrical signal [2][13].

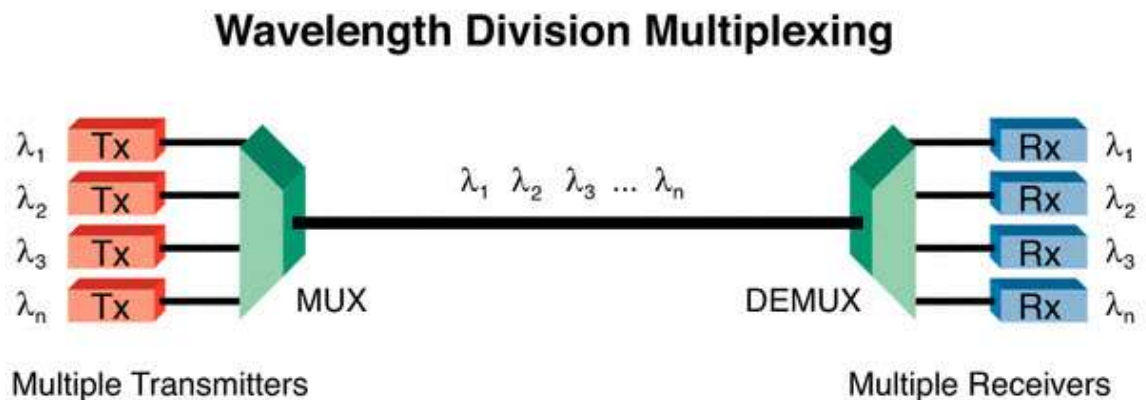

Figure 2.4: Wavelength Division Multiplexing System [36]

Fig. 2.4 shows a WDM system with n channels (wavelengths). The sender has n transmitters, each set to a different wavelength from 1 to n . At the input side, multiplexer combines the signals into one composite signal to be transmitted through the fiber [2]. The input data to be communicated is transformed from electrical to optical form. Similarly, at the receiver side, there are n receivers, each tuned to a different wavelength [2]. The signal is de-multiplexed (separated) and changed into the corresponding wavelength and converted from optical to electrical to recover the original signal at the receiver end [2].

2.4 Routing and Wavelength Assignment

“Each lightpath must be assigned a route over the physical network, and a particular channel on each fiber it traverses [2]”. For increasing the efficiency of wavelength-routed all-optical networks the issue of routing and wavelength assignment is crucial [18]. For a given physical network structure and the resource connections, the RWA problem is to find a feasible path and wavelength for each connection so that no two lightpaths sharing a link have the same wavelength [18].

The main objective of the RWA problem is to establish as many lightpaths as possible, respecting the resource limitations [6]. This helps to minimize the network operation cost and increases the network performance [6]. As can be seen in Figure 2.5 a lightpath is obtained by choosing a path of physical links between the source and destination edge nodes and reserving a particular wavelength on each of these links for the lightpath[6].

There are two main constraints that should be fulfilled for a valid RWA:

- i. Wavelength continuity constraint

ii. Wavelength clash constraint

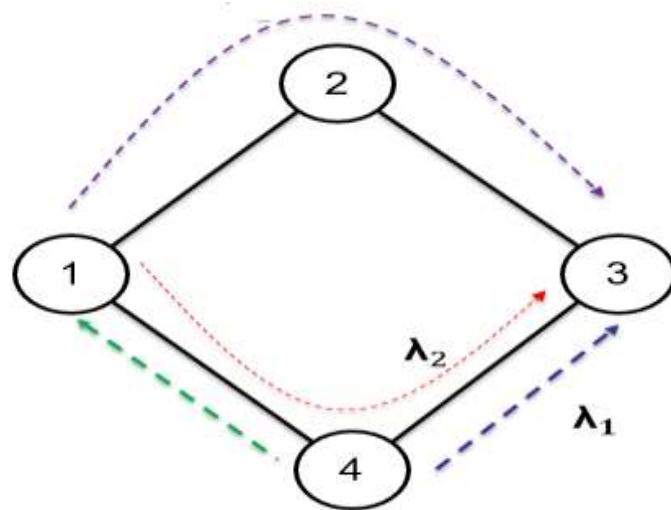

Figure 2.5: Routing Wavelength Assignment

Wavelength continuity constraint states that a lightpath must utilize the same wavelength on all the links along its path from source to destination node [8]. Wavelength clash constraint states that the same wavelength cannot be assigned to more than one lightpath on the same link, at the same time[8].

2.4.1 Energy Aware Routing Wavelength Assignment

The RWA problem has been deeply studied in the literature, and many heuristic algorithms have been suggested to solve it [7]. Two different scenarios can be defined [7]: The Static Lightpath Establishment (SLE) and the Dynamic Lightpath Establishment (DLE). In a case of SLE, classical RWA algorithms aim at minimizing the number of wavelengths needed to support a given traffic matrix; whereas, in DLE, the goal is to minimize the blocking probability. Both the objectives are not consistent with the problem of minimization of the energy consumption.

Traditional RWA algorithms try to minimize the load (e.g., number of wavelengths) on available resources, in order to maximize the probability of accommodating possible new lightpath requests [30]. This leads in general to waste in power required to keep up and running both OXCs and optical amplifiers along fiber links. Hence it is very important to consider the energy-aware RWA problem in order to save energy. “The goal of Energy-Aware RWA problem is to accommodate lightpaths in wavelength routing networks minimizing the power consumption [30].”

2.5 Anycast Routing

Anycasting refers to a strategy of routing data from a source node to any node in a group of potential destinations [20]. In data center networks, the data is replicated at several datacenters and are called replicas. Any one of replicas can be used to provide data to the customers. Such demand routing can be viewed as an anycast request to reach one of the data centers [20-21]. Anycasting makes the datacenter very effective and scalable. In unicast routing, the source node and the destination node for each demand is fixed. In anycast routing, the destination gets selected from the set of possible destinations.

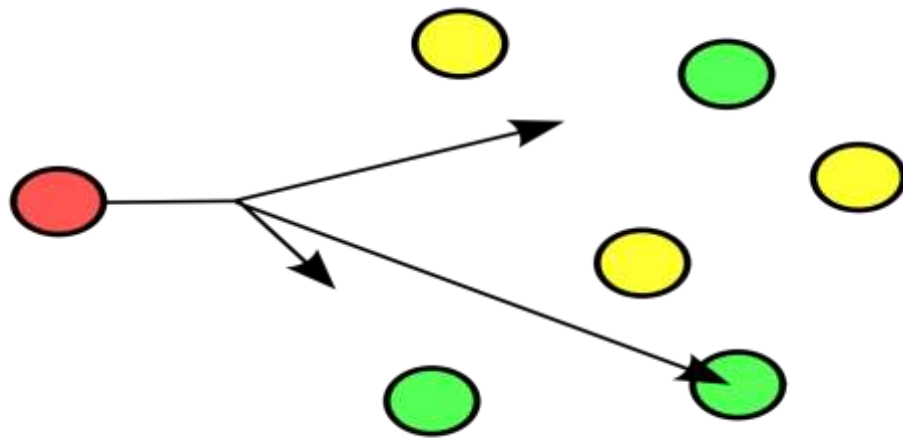

Figure 2.6: Anycast Routing [37]

2.6 Traffic Demand Allocation Models

In optical communication technology, there are three categories of traffic demand allocation models:

- i) Static traffic demand
- ii) Dynamic traffic demand and
- iii) Scheduled traffic demand

In the static traffic demand, the set of lightpaths to be established is known in advance and relatively stable over long periods. The set-up time and tear down time of a demand is also known in advance. For dynamic lightpath demands the arrival time and duration of demands are randomly generated based on a specific distribution [22]. The setup and tear down times are not known in advance. The duration of dynamic lightpath is generally smaller than static lightpath demands. “When a connection (lightpath) is no longer needed, the resources allocated to that lightpath are released and can be used for other lightpaths [39]”. In scheduled lightpath demands (SLD) the demand setup and teardown times are known in advance. The scheduled traffic model further divides into two categories: fixed window demand allocation and sliding window demand allocation [23].

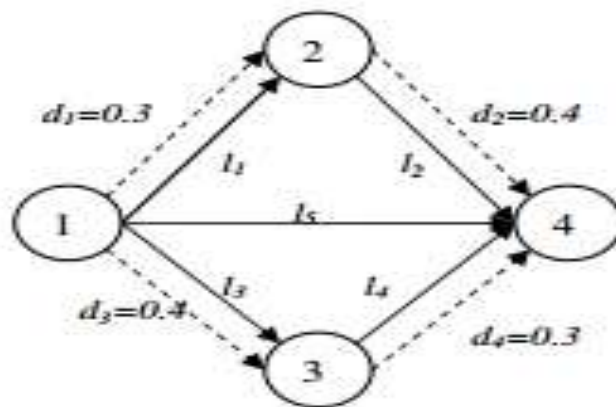

Figure 2.7 Logical Topology and traffic routing [22]

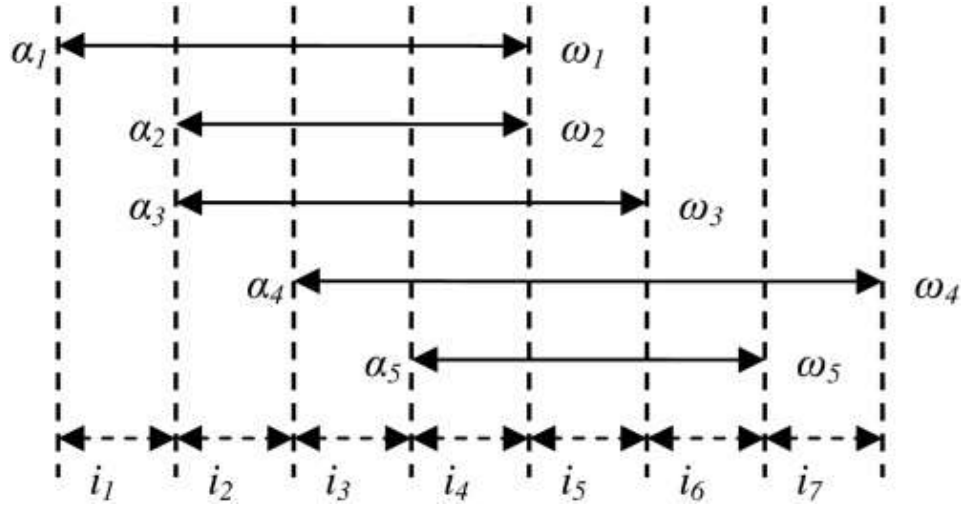

Figure 2.8 Fixed Window Demand Allocation Model [22]

In Figure 2.8, the fixed window demand allocation model is explained. The entire time period of interest is divided into a number of consecutive time intervals ($i_1, i_2, i_3, \dots, i_7$). $\alpha_i (w_i)$ represents the start (end) time for demand d_i . During interval i_3 four demands d_1, d_2, d_3 and d_4 shown as dashed lines in figure 2.7 are routed over the four active lightpaths l_1, l_2, l_3 and l_4 [39]. Lightpath l_5 is inactive as it is not carrying any traffic at this time [39].

“Sliding window model provides some flexibility scheduling the demands in time [39]”. In Figure 2.9 the sliding window demand allocation model is explained. The entire time period of interest is divided into a number of consecutive time intervals ($i_1, i_2, i_3, \dots, i_7$). $\alpha_i (w_i)$ represents the start (end) time for demand d_i . (α, ω) specifies the larger window. As shown in figure 2.9 if d_5 is scheduled to start at the beginning of the interval i_3 instead of i_4 , then the lightpath l_3 can be turned off at the end of interval i_5 . Thus, by appropriately choosing the routes and possibly the start times of the scheduled demands, the number of active lightpaths at any given time is minimized which can lead to energy savings [22].

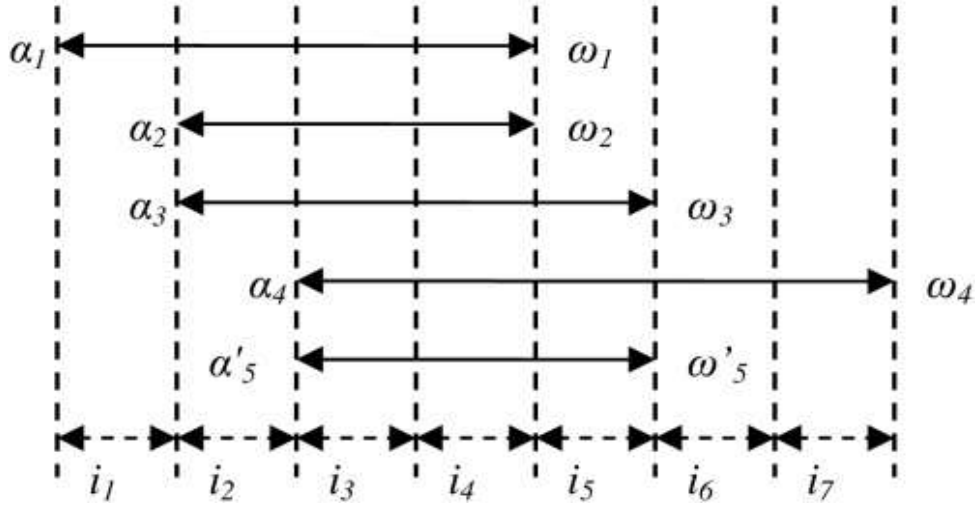

Figure 2.9 Demand scheduling under the sliding window model [22]

2.7 Datacenter

A datacenter can be pictured as a facility that centralizes an organization's IT operations, equipment and also stores, manages and disseminates its data [24]. Data center network (DCN) assumes a critical role in a data center because it integrates all data center resources together. Figure 2.10 refers to one of the datacenters of Facebook.

The resources and data in a datacenter are served to customers through a network of datacenters, which is referred to as the cloud [16]. “The content of datacenters is replicated over multiple datacenters to improve availability and also solves the problem of availability in the event of a disaster (earthquake, tsunami). [2]” Figure 2.11 refers to a six-node topology which shows the data-center nodes in that topology.



Figure 2.10: Datacenter [38]

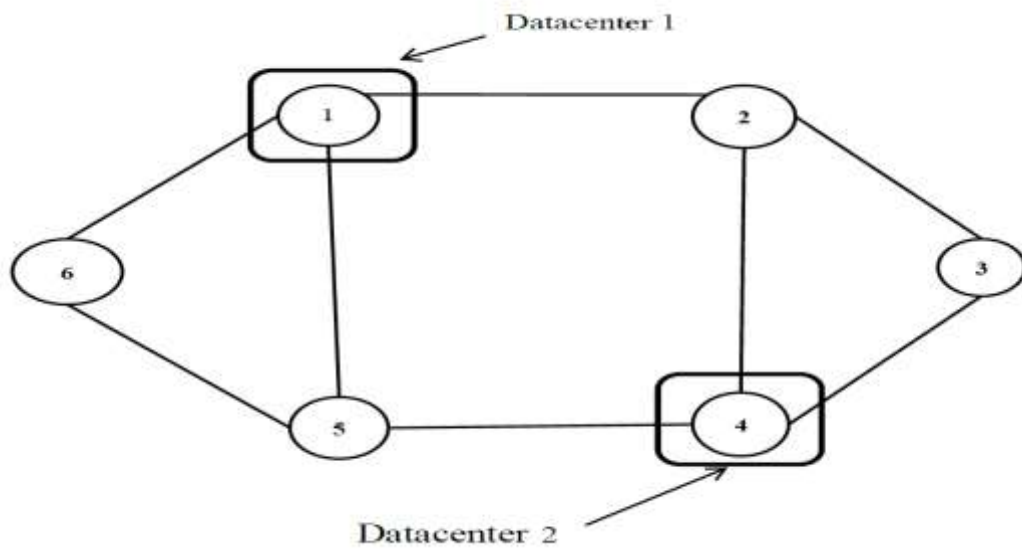

Figure 2.11: Nodes representing datacenters in a network [2]

Cloud administrations transported by datacenter systems produce new chances to give security against catastrophes. In such a network, different contents and services are

replicated over multiple datacenters, so that a user request can be completed by any datacenter that supports the specified content or service [25]. This scheme, where the required content/service can be completed from one of many possible datacenters, is called as *anycast* service [25].

2.8 Lightpath

An optical connection from one end node to another is called a *lightpath*. It starts from an end node, connects several fibers and router nodes, and terminates in another end node [2]. A lightpath may or may not have multiple wavelengths from source to destination, which depends on the wavelength conversion capability of the network [2]. In our work, we assume the wavelength continuity constraint, which requires that the same wavelength be maintained along the entire lightpath.

The Figure 2.12 shows an example of a physical topology with lightpaths. There are five nodes in the network and each node is connected to one or more nodes in the network by bidirectional fiber links (shown by solid black lines). The lightpaths in the following examples are:

Lightpath 1: node 1 → node 4

Lightpath 2: node 1 → node 5

Lightpath 3: node 2 → node 1

Lightpath 4: node 2 → node 3

Lightpath 5: node 3 → node 4

Lightpath 6: node 3 → node 5

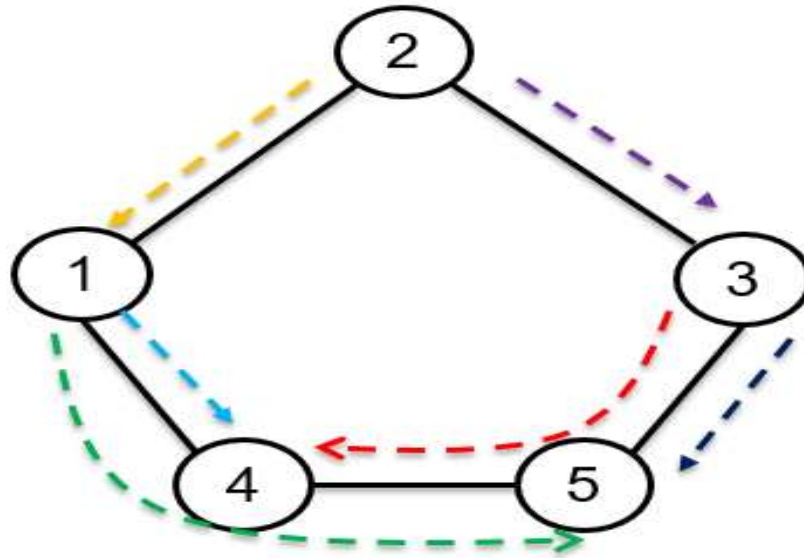

Figure 2.12 Lightpath setup in a 5-node network

2.9 Physical and Logical Topology

A physical topology (shown in Figure 2.13) indicates the actual connectivity, using optical fibers, among the nodes in the network. In the graphical representation, the physical topology is depicted by a graph $G(N, E)$, where N is the set of nodes in the network and E is the set of edges in the network. Each bi-directional link in the physical topology is implemented using two unidirectional optical fiber links.

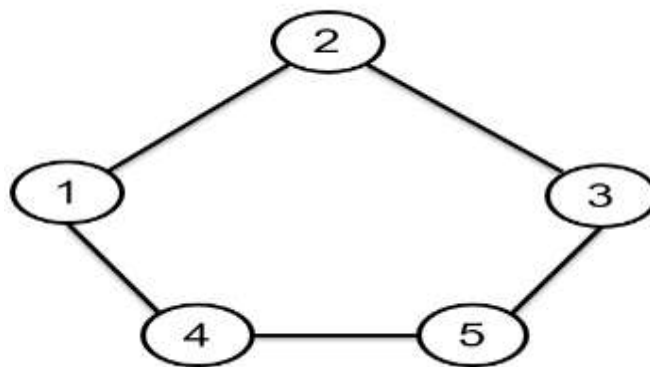

Figure 2.13: Physical Topology

In a *logical* or *virtual* topology[2], the lightpaths are viewed as the edges in the network. The set of nodes is the same as that of the physical topology. Figure 2.14 represents the logical topology that is established over the physical topology in Figure 2.13, using the lightpaths shown in Figure 2.12.

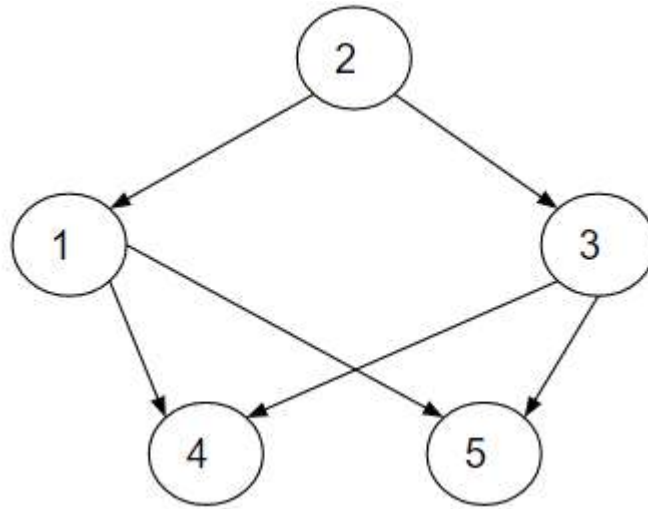

Figure 2.14: Logical Topology

2.10 Literature Review

In this section, we discuss in detail the papers that are directly related to our thesis.

In [1] the authors propose to decrease operational expenditures by picking the route with the least cost for the energy consumed. Adding more replicas improves the reliability and lowers latency across the network, but it also increases the network costs [1]. "In the model proposed in this paper, an object is partitioned, and each piece is replicated at several locations and is called a shard [25]." In this paper, they have considered the RWA problem in which each connection is set up along a physical network route and a single fixed wavelength thereupon. Considering the Real-Time Energy Price (RTP) and replicated data storage architecture, an algorithm called the Least Dollar Path is proposed to find the most cost-effective data source and network route. "They have used a multilayer node model to

calculate the network power consumption [2]”. The node consists of an electrical routing at the top, an optical transport and multiplexing layer at the bottom and a connecting OEO layer in between. WDM is the transport network technology used. Based on this model, they have proposed an equation for the nodal electricity cost, and it can be calculated as the product of the energy consumption of the node and the price that is charged for the node in that duration. The Least Dollar Path routing approach is proposed to achieve minimum electricity cost to transport data. Electricity cost of a path is proportional to the electricity cost in the destination nodes of each link in the path. LDP is a dynamic route calculation technique. The link weights are assigned according to the cost at the destination nodes [27]. The goal of this algorithm is to pick the least expensive route and replica in combination so as to incur the minimum electricity cost. Numerical results show that the LDP approach can reduce electricity cost up to 30% as compared to other algorithms.

In [3] the authors proposed a management scheme whose goal is to minimize the power consumption of DCNs (Data center networks) while maintaining the availability. To support high availability, a requirement of two node-disjoint paths between the source and destinations of each traffic flow is considered. A heuristic approach is also proposed which reduces the power consumption and also improves the availability. This paper focuses on failed loaded network availability which means that the failed traffic can be rerouted through other capable paths. It is assumed that the traffic can only be routed through a pre-decided path. The benefit of having two node-disjoint paths helps the traffic flow routing because even if one fails we still have the other path. An online heuristic approach called Two Node-Disjoint Paths(TNDP) is also proposed to find a practical solution with reasonable computation time. Many studies aiming to save energy in networks have been

proposed in recent years. For e.g., Lin et al. (2014) proposed an energy aware two disjoint paths routing to improve the reliability and the throughput of networks. The problem with this was that it didn't consider node failures that may happen in DCNs. The DCN architecture is mainly classified into 2 categories namely switch-centric architecture such as hypercubes and fat trees which use switches to connect network devices and server centric architecture such as DCells and BCubes which uses servers to act as relay nodes. In the power model presented in this paper, it is assumed that a DCN always has enough bandwidth capacity. To improve the availability, a requirement of 2 node-disjoint paths between source and destination is considered. These two node-disjoint paths are named primary and backup path. The primary path is used actively, and the backup path is used only when the primary path fails. Also, the link capacity of the backup path is reserved. From the studies carried out by Heller et al. and Wang et al. it is shown that the power consumption of a switch depends on the traffic load on the switch. The heuristic approach called TNDP reduces the power consumption and improves the availability of DCN by supporting each traffic flow with two node disjoint paths. TNDP obtains the topology of the DCNs, $G(V,E)$ (set of nodes-V, set of links-E), including link capacity and power model of switches. TNDP finds two node-disjoint paths traffic by traffic and the shorter paths of both the nodes are used as primary paths and the longer ones are used as backup paths. After the two nodes, disjoint paths for this traffic flow are found, TNDP updates the paths and the network utilization. The four topologies which were used for the experiments are fat trees, hypercubes, DCells and BCubes. The basic aim of this paper was to maintain balance between availability and power conservation. For that purpose, the common idea is to merge the traffic flows and switch off unnecessary network devices. It sacrificed

availability hence two disjoint node paths for each flow is considered to reduce the power consumption and maintain the availability of the DCNs. To formulate the problem in mathematical format integer linear program is proposed. Due to its high computational complexity, a heuristic approach is also proposed which achieves nearly optimal solution in fat trees. The heuristic approach reduces the power consumption by 15 to 35% and also improves the availability by about 15% [3]. For future work, this paper plans to consider multipath routing and more topologies in DCNs like DCube, hypercube, butterfly and so on.

In [28], the authors considered the power consumption of the OTN (Optical Transport Network) architectures under different traffic loads and patterns as well as different network physical topologies. There are different types of OTN architectures such as DWDM with high Single Line Rates (SLRs), DWDM with Mixed Line Rates(MLRs) and the OFDM technique. Heuristic algorithms are also developed for the green design and planning of data center optical interconnects. The DWDM technique has been considered as the preferred transport platform technology used for the DCI (Data Center Interconnect). The problem with the SLR architecture is that it leads to inefficient use of spectral resources, as low traffic demands have to be carried by an entire DWDM channel. To cope up with this inefficiency MLR architecture can be preferred because it can provide a better flexibility regarding the use of spectral resources to manage heterogenous traffic demands. Also in this paper, they have investigated the power consumption of using flexible grid technology rather than fixed grid technology in the design and planning of the optical DCI. To achieve this objective, new heuristics has been proposed for the design and planning of the OTN using the SLR, MLR and EON (elastic optical networking)

technologies. They have proposed a new power-aware heuristic for the design and planning of the optical DCI using SLR, MLR and EON technologies employing regeneration sites along the established paths if necessary due to the optical reach constraint of transponders. To investigate the power efficiency using the EON, a framework has also been presented to study the mentioned technologies under different traffic loads and patterns as well as physical topologies. Power efficient design and planning of the data center optical interconnect using the SLR or MLR/EON technology requires solving the RWA/RMLSA problem. Due to the computational complexity of the problem, it is tough to get an optimal solution hence heuristics has been proposed which tries to solve large-sized problems sub-optimally. The main components of the heuristic algorithm consist of creating the multi-granularity demand matrix, determining the availability of the wavelength channel, finding the best route, update the network resources and finally calculating the OTN power consumption. The heuristic proposed is for the design and planning of the green data center optical interconnect. The results show that the greenest architecture depends on the physical topology of the interconnect. Also, elastic optical networks can provide more savings if the traffic pattern is non-uniform. They are currently working on developing an ILP to validate their green heuristic approach [39].

In [33] the authors propose anycast principle to decrease energy consumption in optical networks and server systems. Their proposed approach evaluates power consumption on networks with wavelength conversion and without conversion [39]. The approach they utilized to solve the problem was to effectively select the destination through anycast routing from the set of possible destinations by switching off unused network elements [39]. The authors evaluate possible energy saving for the optical network through

allowing full wavelength conversion capability. The inputs to the problem formulation are the network topology with optical cross connects and fiber links, which are used to connect them, along with source nodes and destinations [33][39]. The goal is to find routes in the topology in such a way that it reduces the overall power consumption. The authors compare their proposed anycast routing scheme with unicast routing. They also compared the results for wavelength conversion and wavelength continuous networks [33][39]. The authors conducted experimentation on COST-239 European networks with having 11 nodes and 26 links [19]. The numbers of candidate server destination sites are 3, and each fiber supports 16 wavelengths. The authors claim that the power consumption in fiber links accounts for 30%, while OXC 24 and other network node consumes 70% of total power consumption [33][39]. The results obtained by authors show 23% less power consumption for anycast. “The authors also claim to have 20% energy consumption reduction and 29% reduction of wavelength resource usage with anycasting compared to traditional unicasting approach [39]”.

In [23] the authors address the problem of energy-aware routing of scheduled demands in optical grids. They have proposed a novel approach for energy-aware routing in optical grids [39]. “They have proposed an optimal integer linear program (ILP) formulation for selecting routes and destinations to minimize the total energy consumption of a set of scheduled lightpath demands [39]”. The ILP helps in jointly performing node selection and RWA with the goal of minimizing the overall energy consumption [39]. “The approach used in this paper takes into consideration energy consumption at the network nodes and along the optical fibers, as well as the start time and duration of each scheduled demand” [39]. They have considered a set of scheduled lightpath demands (SLD), where

each demand p can be executed at a node dp , which is selected from a set of possible destination nodes Dp [39]. Optical grids are very useful for large-scale computing and has data transmission capabilities in a number of emerging application areas. They exploit the inherent flexibility of anycasting for energy efficient routing in optical grids under the scheduled traffic model. Their simulation results show that significant energy savings can be achieved compared to both traditional energy-unaware RWA algorithms and more recent energy - aware unicast RWA algorithms.

In [20] the authors propose a new approach to energy aware resource allocation for optical grids that uses the built-in flexibility of anycasting [1]. Optical grids are very valuable for large-scale computing and have data transmission capabilities in a number of developing application areas. They utilize the inherent flexibility of anycasting for energy efficient routing in optical grids under the static traffic model. They have considered a set of static lightpath demands, originating at different sources, to be established over a physical fiber network. Each demand i can be executed at a node di , selected from a set of possible destination nodes Ni . They have presented an integer linear program (ILP) formulation that selects the destination node and performs an optimal RWA, with the goal of minimizing the overall energy consumption for a set of static lightpath demands. They have also presented a 2-stage ILP that can quickly generate solutions for large networks. Simulation results indicate that significant energy savings can be achieved by the proposed approach, not only compared to traditional RWA techniques but also over energy-aware unicast methods.

2.11 Summary of Literature Review

Table 2.1: Literature Review Summary

Reference	Traffic Granularity	Traffic Model	Routing Scheme	Solution Approach
Deylamsalehi et al. 2016	Lightpath	Static	Anycasting	Heuristic
Jiang et al. 2016	Lightpath	Static	Unicasting	ILP/Heuristic
Buysee et al. 2011	Sub-wavelength	Static	Anycasting	ILP
Chen et al. 2014	Lightpath	Scheduled	Anycasting	ILP
Chen et al. 2013	Lightpath	Static	Anycasting	ILP

CHAPTER-3

ENERGY EFFICIENT ANYCAST ROUTING FOR FIXED WINDOW SCHEDULED TRAFFIC MODEL

3.1. Introduction

This chapter introduces the proposed ILP using *anycast* principle for fixed window scheduled lightpath demands allocation. The total power utilized by networking elements in data centers in 2014 in the U.S. was 3 billion kWh and rising [40]. There is a strong need to reduce this rapidly growing energy cost. The objective here is to minimize the overall electricity costs of a data center network by reducing the actual energy consumption.

3.2. Network Energy Model

We consider a transparent IP-over-WDM network, which consists of optical cross connect switches connected to IP router [23][39]. We consider power consumption both at network nodes and fiber links [23]. The total power consumption by IP router, optical switch and fiber links can be calculated using following equations.

$$P_{IP} = P_{IP_low} + P_{IP_ON} + P_{IP_dyn} * t_{IP} \quad (3.1)$$

$$P_{SW} = P_{SW_low} + P_{SW_ON} + P_{\lambda} * t_{\lambda} \quad (3.2)$$

$$P_e = P_{pre} + P_{post} + P_{inline} \quad (3.3)$$

In both cases, P_{IP} and P_{SW} , the first term P_{IP_low} and P_{SW_low} define the power consumption of an IP router and a switch at a low power state or inactive state when no traffic is passing through it. The second terms P_{IP_ON} and P_{SW_ON} denotes the *static* power consumption for turning the IP router and the switch on so that it can carry some traffic.

The third terms P_{IP_dyn} and P_{λ} is the *dynamic* component of the power consumption of the

IP router and the switch, which rises with the amount of traffic passing through the node [39]. The terms t_{IP} and t_{λ} indicate the amount of traffic flowing through the IP router and switch [39]. The last equation P_e denotes the power consumption of an active fiber link [39]. It is the addition of power consumption of all active pre, post and inline active amplifiers [39]. Each fiber link e has one pre and one post amplifier and one or more inline amplifiers, depending on the length of the link. Table 3.1 shows the power consumption of different network devices considered in this thesis.

Table 3.1: Power consumption of network devices [41], [42]

Device	Symbol	Power Consumption
IP router (static)	P_{IP}^S	150 W
OXC (static)	P_{OXC}^S	100 W
IP router (dynamic)	π_{IP}	17.6 W
OXC (dynamic)	π_{OXC}	1.5 W
Transponder/OEO (dynamic)	π_{XT}	34.5 W
Pre-amplifier	P_{pre}	10 W
Post-amplifier	P_{post}	20 W
Inline amplifier	P_{inline}	15 W

3.3 Solution Approach

Data Centers have become one of the fastest growing consumers of electricity. Higher energy consumption leads to higher economical costs and affects the environment. Flat rate pricing model leads to more electricity costs as compared to the real-time pricing model [1]. Efficient routing schemes and proper arrangement of the replicas can lower energy consumption and help reduce costs for the data centers [1].

Our approach to addresses the cost minimization problem is by developing energy efficient routing schemes to minimize the overall electricity costs of a network by reducing the actual power consumption. We have considered the real-time pricing model for the electricity prices as real-time prices consider the price changes throughout the day and also to select routes for a lightpath. We consider a set of fixed window lightpath demands originating from different sources and select the route and destination for each demand in such a way that that the prices are minimized [39]. We have developed an integer linear program (ILP) formulation to solve this integrated routing and scheduling problem.

The ILP performs EA-RWA (Energy aware routing and wavelength assignment) for fixed window traffic model. The objective of the ILP is to minimize the electricity costs of a data center network by reducing the actual energy consumption through energy efficient routing. The constraints find the optimal route to a suitable destination based on *anycast* and try to minimize the overall electricity cost.

3.4 Proposed ILP

In this section, we present our ILP formulation for energy aware RWA of scheduled lightpath demands under the fixed window traffic model. The notation is used in our ILP is given below.

Inputs

- Physical topology $G [N, E]$
- N : Set of nodes in the network
- E : Set of edges in the network
- S : Set of datacenter nodes
- R : files replicas at datacenter nodes
- Q : Set of scheduled lightpath demands to be routed over the physical topology
- (i, j) : edge in the network from node i to node j
- Set of lightpath demand requests (s_q, st_q, τ_q) , where s_q is the source (destination node), st_q is the starting time for each demand and τ denotes the holding time for each demand
- $m = 0, 1, 2 \dots m_{max}$, m is the number of intervals ($0 \leq m \leq 23$)
- M : a large constant, M is the large constant that represents the entire time duration
- $P_{IP}^s, (P_{OXC}^s)$: static component of IP router power consumption (OXC switch)
- $a_{q,m} = 1$ if demand q is active during interval m
- l_e : length of edge e

Binary Variables

- $IP_{i,m} = 1$, if IP router at node i active at interval m
- $OXC_{i,m} = 1$, if OXC at node i is active at interval m
- $OEO_{i,m} = 1$, if OEO at node i is active at interval m
- $L_{e,m} = 1$, if link e is in use at interval m
- $x_{q,e} = 1$, if lightpath q uses link e
- $y_{q,i} = 1$, if lightpath q uses node i

➤ $dc_{q,i} = 1$, if DC node i is selected as a destination for lightpath q

Bounded Variables

➤ $\beta_{i,m}^q = 1$, if lightpath q uses IP router at node i during interval m

➤ $\gamma_{i,m}^q = 1$, if lightpath q uses OXC at node i during interval m

➤ $\sigma_{e,m}^q = 1$, if lightpath q uses link e during interval m

ILP formulation

Obj 1 (minimize dollar cost): Minimize

$$\sum_m \left[\sum_i cost_{i,m} \left[P_{IP}^S \cdot IP_{i,m} + \pi_{IP} \sum_q \beta_{i,m}^q + \left(P_{OXC}^S \cdot OXC_{i,m} + \pi_{OXC} \sum_q \gamma_{i,m}^q \right) + \left(\pi_{XT} \sum_q \beta_{i,m}^q \right) \right] + cost_{j,m} \sum_{e:(i,j)} P_e \cdot L_{e,m} \right]$$

(3.4)

Subject to:

RWA:

$$\sum_{e:(i,j) \in E} x_{q,e} - \sum_{e:(i,j) \in E} x_{q,e} = \begin{cases} dc_{q,i} & \text{if } i = \text{source (DC)} \\ -dc_{q,i} & \text{if } i = \text{destination} \\ 0 & \end{cases} \quad \forall i \in N, q \in Q$$

(3.5)

$$y_{q,i} = \sum_{e:(i,j) \in E} x_{q,e} \quad \forall i \in N, q \in Q$$

(3.6)

$$\sum_q x_{q,e} \cdot a_{q,m} \leq |K| \quad \forall e \in E, m \in M \quad (3.7)$$

$$\sum_{i \in S} dc_{q,i} = 1 \quad \forall q \in Q; \quad dc_{q,i} = 0 \quad \forall i \notin S, q \in Q \quad (3.8)$$

IP router usage:

$$dc_{q,i} + a_{q,m} - \beta_{i,m}^q \leq 1 \quad \forall i \in S, q \in Q, m \in M \quad (3.9)$$

$$dc_{q,i} \geq \beta_{i,m}^q \quad \forall i \in S, q \in Q, m \in M \quad (3.10)$$

$$a_{q,m} \geq \beta_{i,m}^q \quad \forall i \in S, q \in Q, m \in M \quad (3.11)$$

$$IP_{i,m} \geq \beta_{i,m}^q \quad \forall i \in S, q \in Q, m \in M \quad (3.12)$$

$$IP_{i,m} \leq \sum_q \beta_{i,m}^q \quad \forall i \in S, m \in M \quad (3.13)$$

OXC switch usage:

$$(dc_{q,i} + y_{q,i}) + a_{q,m} - \gamma_{i,m}^q \leq 1 \quad \forall i \in N, q \in Q, m \in M \quad (3.14)$$

$$(dc_{q,i} + y_{q,i}) \geq \gamma_{i,m}^q \quad \forall i \in N, q \in Q, m \in M \quad (3.15)$$

$$a_{q,m} \geq \gamma_{i,m}^q \quad \forall i \in N, q \in Q, m \in M \quad (3.16)$$

$$OXC_{i,m} \geq \gamma_{i,m}^q \quad \forall i \in N, q \in Q, m \in M \quad (3.17)$$

$$OXC_{i,m} \leq \sum_q \gamma_{i,m}^q \quad \forall i \in N, m \in M \quad (3.18)$$

Link usage:

$$x_{q,e} + a_{q,m} - \sigma_{e,m}^q \leq 1 \quad \forall e \in E, q \in Q, m \in M \quad (3.19)$$

$$x_{q,e} \geq \sigma_{e,m}^q \quad \forall e \in E, q \in Q, m \in M \quad (3.20)$$

$$a_{q,m} \geq \sigma_{e,m}^q \quad \forall e \in E, q \in Q, m \in M \quad (3.21)$$

$$L_{e,m} \geq \sigma_{e,m}^q \quad \forall e \in E, q \in Q, m \in M \quad (3.22)$$

$$L_{e,m} \leq \sum_q \sigma_{e,m}^q \quad \forall e \in E, m \in M \quad (3.23)$$

3.4.1. Justification of the ILP

The objective function in (3.4) tries to minimize the dollar cost by using the real-time electricity prices. The term $cost_{i,m}$ is the real time electricity price at node i during interval m . We have 24 intervals and for each interval the electricity price is different. Hence accordingly, the costs will be multiplied by each term in the function. We have an array of values which are the real-time electricity prices at node i during interval m . Based on the values of i and m the variable $cost_{i,m}$ will be equal to one of the values in the array.

For calculating the cost of a link $e: i \rightarrow j$, we have multiplied the energy consumption of the link e with cost at the destination node j of that link.

Constraint (3.5) is the standard flow conservation constraint, which is used to find a feasible path from source node s_q to the selected destination node $dc_{q,i}$ for each demand q . Constraint (3.6) ensures that if lightpath q traverses link $e: (i, j)$ the value of $y_{q,i}$ is set to 1, which means that lightpath q uses node i . Constraint (3.7) ensures that the total number of demands traversing link $e: (i, j)$ does not exceed the number of available channels K . Constraint (3.8) ensures that value of the variable $dc_{q,i}$ is equal to 1 and it is selected as the destination node for lightpath q .

Constraints (3.9) – (3.13) are the *router usage* constraints. They are used to determine if a particular IP router at node i is active during interval m . Constraints (3.9) – (3.11) are used to set the value of $\beta_{i,m}^q$. Constraint (3.9) sets $\beta_{i,m}^q = 1$ if lightpath q is active during interval m and DC node i is selected as a destination for lightpath q . Constraints (3.10) and (3.11) ensure that $\beta_{i,m}^q = 0$, if either $dc_{q,i} = 0$ or $a_{q,m} = 0$. Constraint (3.12) ensures that if the IP router is active at node i during interval m if it is used by at least one lightpath q . Constraint (3.13) ensures that if there is no lightpath q using IP router at node i during interval m then the IP router is not active during interval m , i.e., $IP_{i,m} = 0$.

Constraints (3.14) – (3.18) are the *optical switch usage* constraints. They are used to determine if a particular optical switch at node i is active during interval m . Constraints (3.14) – (3.16) are used to set the value of $\gamma_{i,m}^q$. Constraint (3.14) sets $\gamma_{i,m}^q = 1$ if lightpath q is active during interval m , it uses the OXC at node i . Constraints (3.15) and (3.16) ensures that $\gamma_{i,m}^q = 0$, if either $dc_{q,i+y_{q,i}} = 0$ or $a_{q,m} = 0$. Constraint (3.17) ensures that the OXC switch is active at node i during interval m if it is used by at least one lightpath q .

Constraint (3.18) ensures that if there is no lightpath q , using OXC switch at node i during interval m , then the OXC switch is not active during interval m , i.e., $OXC_{i,m} = 0$.

Constraints (3.19) – (3.23) are the *link usage* constraints. They are used to determine if a particular link is active during interval m . Constraints (3.19) – (3.21) are used to set the value of $\sigma_{e,m}^q$. Constraint (3.19) sets $\sigma_{e,m}^q = 1$ if lightpath q uses link e and is active during interval m . Constraints (3.20) and (3.21) ensures that $\sigma_{e,m}^q = 0$, if either $x_{q,e} = 0$ or $a_{q,m} = 0$. Constraint (3.22) ensures that link e is active during interval m if it is used by at least one lightpath q . Constraint (3.23) ensures that if there is no lightpath q , using link e during interval m , then the link is not active during interval m , i.e., $L_{e,m} = 0$.

3.5 Some Alternative Objective Functions

In this section, three more objective functions are defined to support the proposed ILP formulation. All these objective functions are proposed for the same set of constraints stated in Section 3.4.

3.5.1 Objective function 2 (minimize hops):

An alternative objective function is proposed to minimize the hops or intermediate nodes traversed.

$$\text{Minimize } \sum_q \sum_e x_{q,e} \quad (3.24)$$

The objective function in (3.24) tries to minimize the number of links or hops used to route the lightpaths in the network. It selects nearest data center capable of supporting the connection request and finds routes with a minimum number of intermediate nodes

between source and any destination. $x_{q,e}$ is a variable which will be set to 1 if lightpath q uses link $e: (i, j)$.

3.5.2 Objective function 3 (minimize distance):

The objective function in (3.25) tries to minimize the distance between the data center nodes and the source nodes. It finds the path with minimal fiber distance between a user and the selected destination. l_e is the length of the link e (from a node i to a node j), and it is specified and known beforehand for all different types of topologies.

$$\text{Minimize } \sum_q \sum_e l_e \cdot x_{q,e} \quad (3.25)$$

3.5.3 Objective function 4 (minimize energy) :

An alternative objective function is built for the purpose of minimizing energy. The objective function in (3.26) tries to minimize the overall energy consumption of the network, for all the components under consideration, i.e., the IP routers, the OXC switches and the amplifiers. This is different from the original objective function in eqn (3.4), which minimizes the overall *cost*.

Minimize

$$\begin{aligned} \sum_m \left[\sum_i \left(P_{IP}^s \cdot IP_{i,m} + \pi_{IP} \sum_q \beta_{i,m}^q \right) + \sum_i \left(P_{OXC}^s \cdot OXC_{i,m} + \pi_{OXC} \sum_q \gamma_{i,m}^q \right) \right. \\ \left. + \sum_i \left(\pi_{XT} \sum_q \beta_{i,m}^q \right) + \sum_e P_e \cdot L_{e,m} \right] \end{aligned} \quad (3.26)$$

3.6 An Illustrative Example

To illustrate the effectiveness of the proposed approach, we consider a simple six node topology with three lightpath demands. The physical topology used in this example is depicted in the figure 3.1 (a). It is a 6-node topology with 8 bi-directional links. The label on each represents the length of the link in Km. Nodes 2 and 3 are identified as the data center nodes, which will serve as potential destinations for the connection (lightpath) requests.

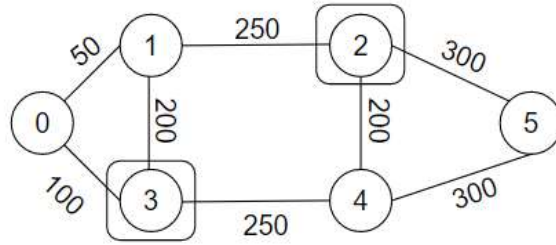

(a)

	s_q	st_q	τ_q
LP0	1	5	8
LP1	4	4	15
LP2	5	0	7

(b)

Figure 3.1: (a) A sample physical topology and (b) A sample set of lightpath requests

A set of three lightpath requests is given in the figure 3.1 (b), where s_q indicates the source node, st_q indicates the starting time interval for that demand and τ_q indicates the holding time for the demand, in terms of the number of time intervals. For example, according to the lightpath requests table, the lightpath LP0 originates from node-1, at interval 5 and is active for a total of 8 intervals. Based on the objective, our ILP selects the appropriate destination (i.e., data center node) and finds the ‘best’ route to the selected destination. The numbers on the edges indicate the distance between the nodes.

As shown in Table 3.2 we have 4 objective functions. The first objective function is to minimize the number of hops. It finds routes with minimum number of intermediate nodes between source and any destination. In the first row of the table, we have the minimized value for that objective which is obtained by running simulations with three demand sets. We have stored the value for other objectives in the other columns as well for comparison. The other columns correspond to values for the total distance traversed, energy consumed and electricity prices. Figure 3.2 shows the routing of lightpath demands on the given physical topology for Objective 1. The second objective function is to minimize the distance. It finds the path with minimal fiber distance between user and any destination. The second row in the table indicates the minimized value for this objective and also the stored value for other objectives are stored in other columns. Figure 3.3 shows the routing of lightpath demands on the given physical topology for Objective 2. As compared to Figure 3.2, we can see how our ILP reroutes the demand to minimize the distance and selects a suitable destination. The third objective function is to minimize the energy consumption by the router, switches and the amplifiers. The third row in the table indicates the minimized value for this objective and contains the value for other objectives. Figure 3.4 shows the routing of lightpath demands on the given physical topology for Objective 3. The fourth objective function which is our main objective is to minimize the dollar costs. As previously mentioned, our ILP tries to minimize the dollar costs by reducing the power consumption in the data center networks. The fourth row in the table indicates the minimized value for this objective which are the electricity prices. The other columns contain the value for other objectives. We can see from the Table 3.2 that as we try to minimize dollar costs or electricity prices the value for number of hops, distance and

energy consumption increased. Figure 3.5 shows the dollar cost at the destination nodes on the edges. Figure 3.5 shows the routing of lightpath demands on the given physical topology for Objective 4.

Table 3.2: Minimized Value for Objectives

Obj. minimized	Hops	Path length (km)	Energy consumption (kwh)	Dollar cost (\$)
Obj. 1	3	700	7.8	0.18
Obj. 2	4	650	7.8	0.18
Obj. 3	3	750	7.0	0.16
Obj. 4	4	750	7.9	0.04

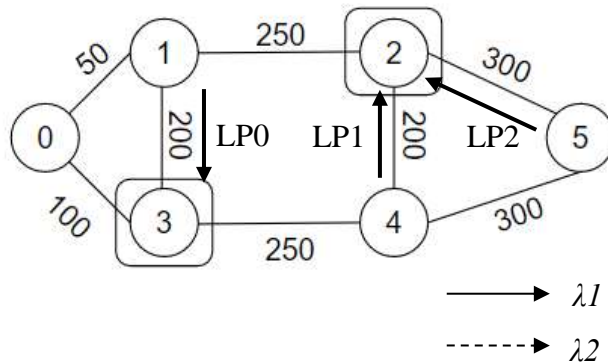

Figure 3.2: Routing of lightpath demands for objective 1

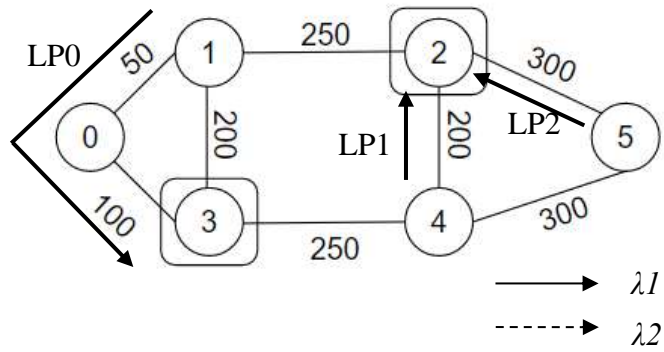

Figure 3.3: Routing of lightpath demands for objective 2

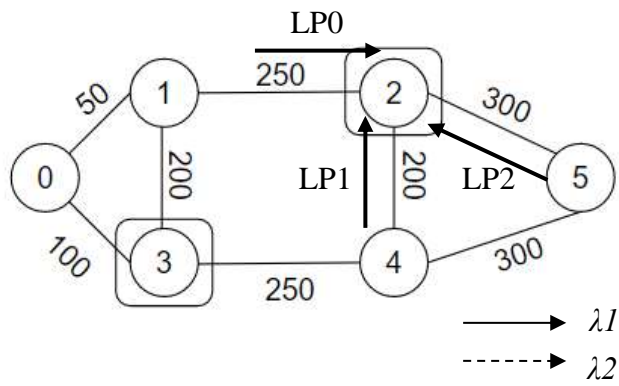

Figure 3.4: Routing of lightpath demands for objective 3

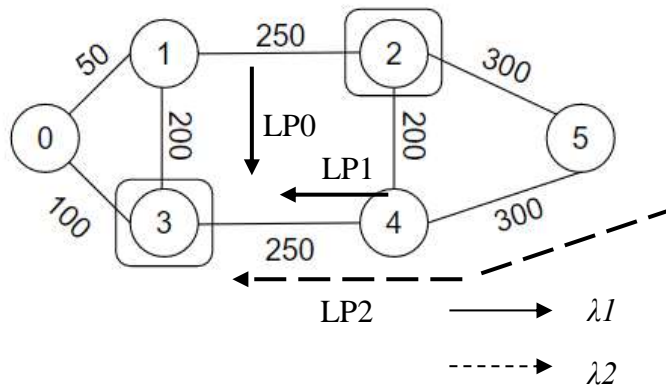

Figure 3.5: Routing of lightpath demands for objective 4

CHAPTER 4

EXPERIMENTATION AND RESULTS

In this chapter, we present experimental results, obtained using our proposed ILP formulations. The ILP can produce optimal results for practical sized problems [39]. Our ILP formulation considers all possible paths between source node and destination node in order to give optimal results [39].

4.1. Simulation Parameters

To perform experiments for our proposed ILP formulations, we considered three well-known topologies ranging in size from 11 nodes to 24 nodes. This includes the standard NSFNET [20] and COST-239 [20] topologies as shown in Figure 4.1 – 4.3. In our experimentation, we have considered the network size ranging from 11-24 nodes as we are addressing the network which supports a large volume of data transmission with relatively high speed like data-center networks. We have performed experiments considering 10, 20, 40 and 80 lightpaths. The holding time ranges from 4 hours to 15 hours, and approximately it is 5 hours on average. The simulation was run 5 times for each specified demand size and specified network topology [39]. We have considered number of factors for demand set such as length of the links, the number of available destination nodes and the distribution of demands [39]. The results obtained from the simulations correspond to average values (rounded to the nearest integer) over different experiment runs. The simulation was carried out with IBM ILOG CPLEX 12.6.2. For each given network topology, we have tested our proposed approach with different sized demand sets [39].

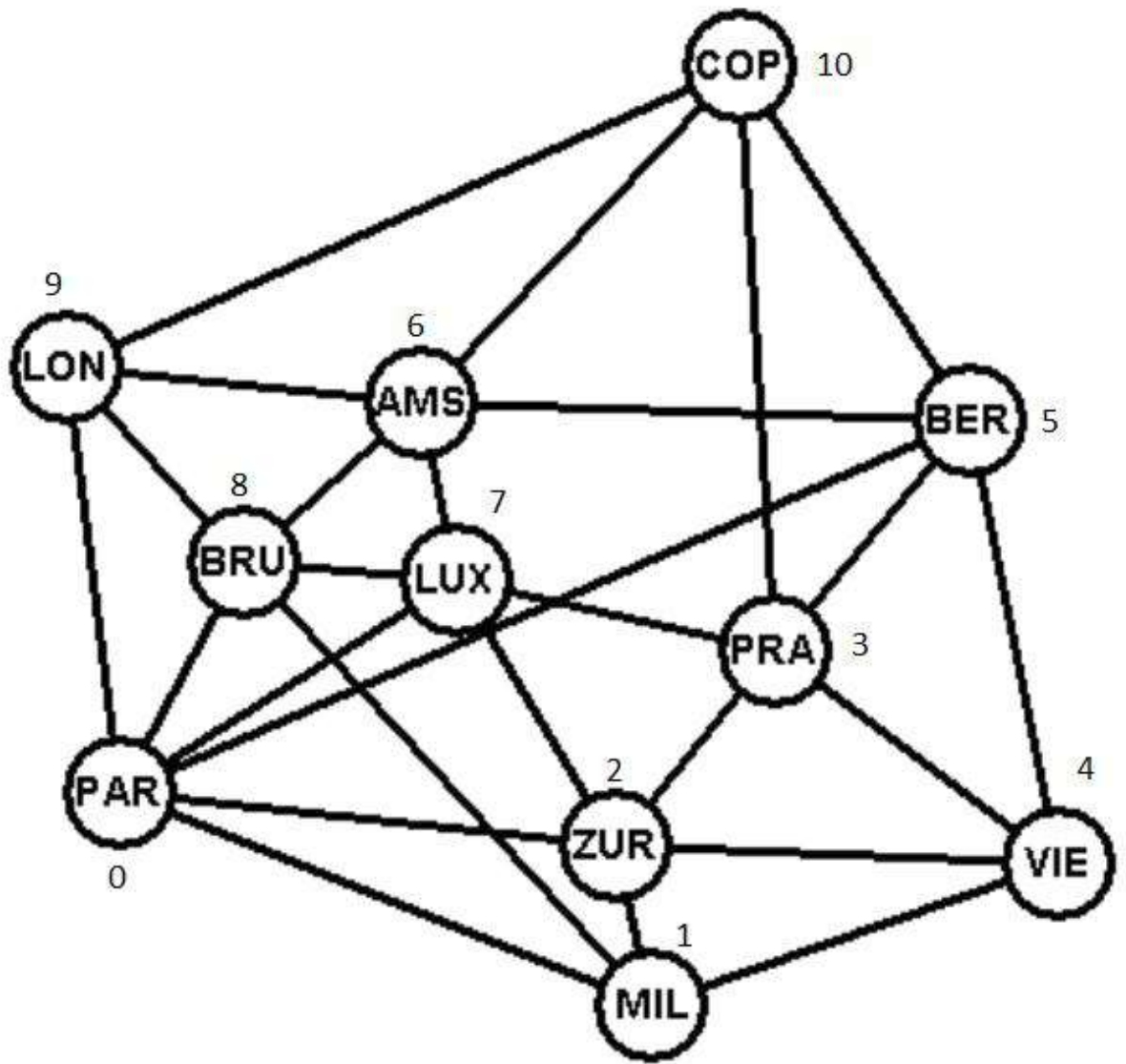

Figure 4.1: Topology 11-node network: 24 links (COST-239)

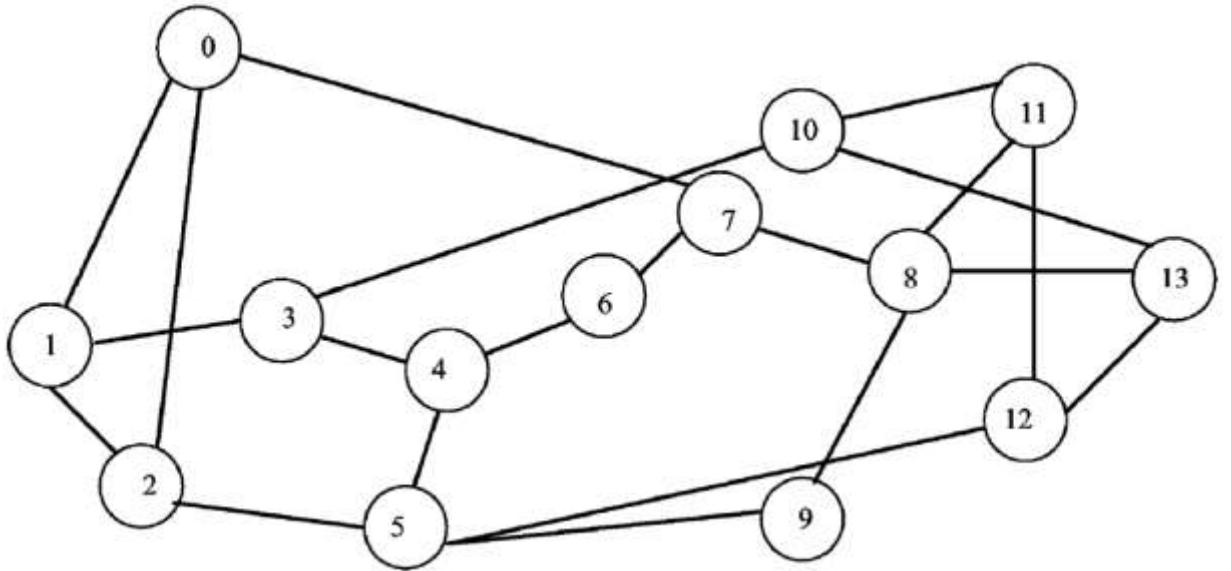

Figure 4.2: Topology 14-node network: 21 links (NSFNET)

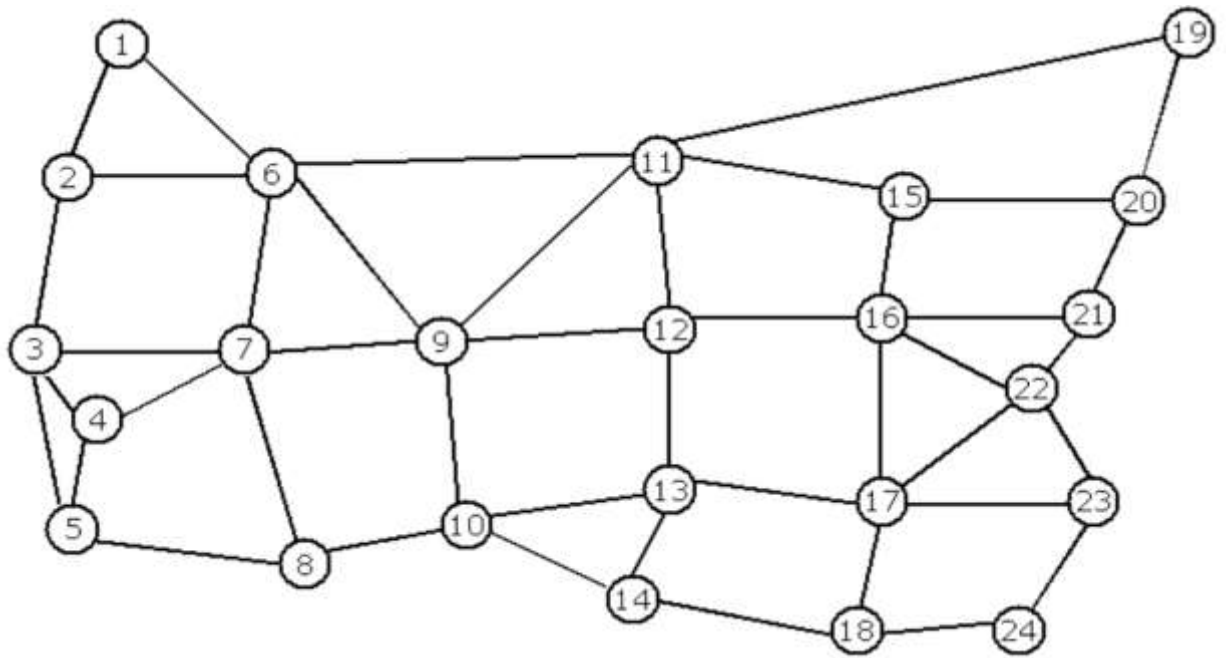

Figure 4.3: Topology 24-node network: 43 links

4.2 Comparison of experimental results

In this section, various simulation results for the proposed ILP formulations with different sizes of demand sets and network topologies are presented. We considered 4 different metrics for the calculated routes:

- i) the total number of hops
- ii) the total path length (in km)
- iii) the total energy consumption (in kWh) and
- iv) the total cost (in \$)

The four objective functions considered each minimize one of these objectives as discussed in Chapter 3. The value of all 4 metrics are calculated using each objective function and reported in Sec 4.2. Each reported value in Sec 4.2 is the average of five simulation results.

4.2.1 Comparison of different network topologies

In this section, simulations are performed for different sizes of network topologies ranging from 11 nodes to 24 nodes and on the same number of demands (40 demands). Table 4.1 shows the values of all 4 metrics obtained using Objective 1 for different topologies. This allows us to see the trade-off among different metrics when using different objective functions. Objective 1 tries to minimize the number of links or hops used to route the lightpaths in the network. From this table, we can conclude that the minimized value for Objective 1 is almost same as the number of demands which means that each request is routed using a single hop. Table 4.2 contains the metrics obtained using Objective 2. It finds the path with minimal fiber distance between user and any destination. From this table, we can observe that as we try to minimize the distance the value for the number of

hops (which is minimized in Objective 1) increases, so we can conclude that minimizing distance is at the cost of number of hops.

Table 4.1: Metrics obtained using Objective 1 (40 Demands)

Nodes	No. of hops	Path length (km)	Energy consumption (kWh)	Dollar cost (\$)
11	40	20320	47.24	1.67
14	50	78180	47	1.72
24	42.2	44326.8	79.26	2.01

Table 4.2: Metrics obtained using Objective 2 (40 Demands)

Nodes	No. of hops	Path length (km)	Energy consumption (kWh)	Dollar cost (\$)
11	40	12568	49.02	2.12
14	55	66360	46	1.70
24	48.2	35460	76.58	2.14

Table 4.3: Metrics obtained using Objective 3 (40 Demands)

Nodes	No. of hops	Path length (km)	Energy consumption (kWh)	Dollar cost (\$)
11	73	33696	41.18	1.36
14	97	169560	35	1.45
24	58.2	42950	67.8288	1.68

Table 4.4: Metrics obtained using Objective 4 (40 Demands)

Nodes	No. of hops	Path length (km)	Energy consumption (kWh)	Dollar cost (\$)
11	70.8	32905	50.66	0.83
14	103	173060	38	0.63
24	56.2	39530	69.3	1.37

Table 4.3 and Table 4.4 shows the calculated values for different metrics obtained using Objective 3 and Objective 4 respectively. Objective 3 tries to minimize the energy consumption by the router, switches and the amplifiers. Objective 4 tries to minimize the dollar costs by using nodes and links for which the electricity cost is lower. From Table 4.3 we can observe that by minimizing the energy consumption, the values for the number of hops and path length has increased and value for overall cost is reduced as compared to

Table 4.1 and Table 4.2. So, we can say that minimizing energy is at the cost of hops and distance, but it reduces the dollar cost as compared to the values obtained by minimizing Objective 1 and Objective 2. Table 4.4 shows the minimized value for the dollar costs. From Table 4.4 we can see how much our ILP minimizes the costs as compared to other objectives. As for Objective 3, this is also at the cost of number of hops and distance. Objective 4 may also increase the total energy consumption. This means that when minimizing Objective 4, the requests may use longer routes and paths that lead to higher energy consumption if the *cost* of energy for those links/nodes is significantly lower.

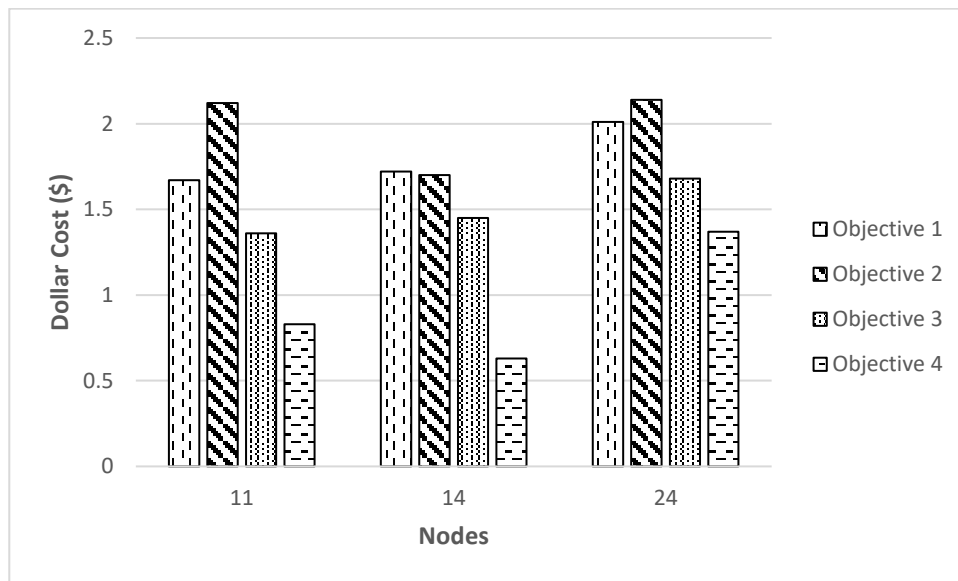

Figure 4.4: Overall Dollar Cost with different Objectives for different topologies (40 Demands)

Figure 4.4 shows the graphical representation of dollar costs for routing 40 demands, over different topologies (11-node, 14-node, 24-node), when different objectives are used for calculating the routes. The x-axis represents the number of nodes in the topology (11, 14 and 24) and the y-axis shows the costs in dollars. From the graph, we

observe that (as expected) our main objective function (Objective 4), which minimizes the electricity cost, has the lowest dollar cost for all cases. The improvement ranges from 22.6% - 56.5% over the next best performing value, which is obtained using Objective 3 (minimize energy consumption) for all three topologies.

4.2.2 Comparison of different demand sizes:

In this section, simulations are carried out for different demand sizes ranging from 40 to 120 numbers of demands under the 14 - node topology. Table 4.5 shows the values for the 4 metrics, corresponding to different traffic loads obtained using Objective 1, for the 14-node topology. Simulations are also carried out for 11-node and 24-node topologies as well, and results follow a similar pattern. A standard growth is observed in the all 4 metrics with an increase in the demand size.

Table 4.5: Metrics obtained using Objective 1 (14 – node topology)

No. of Demands	No. of hops	Path length (km)	Energy consumption (kWh)	Dollar cost (\$)
40	50	78180	47	1.72
80	109.4	180320	73.54	2.62
100	136	181400	82.6	2.67
120	165	202900	92	3.3

Table 4.6: Metrics obtained using Objective 2 (14–node topology)

No. of Demands	No. of hops	Path length (km)	Energy consumption (kWh)	Dollar cost (\$)
40	55	61360	46	1.70
80	217	63244.06	69.6	2.17
100	245	160400	77.7	2.50
120	311.4	181680	83.48	2.83

Table 4.7: Metrics obtained using Objective 3 (14–node topology)

No. of Demands	No. of hops	Path length (km)	Energy consumption (kWh)	Dollar cost (\$)
40	97	169560	35	1.45
80	212.8	332020	61.6	1.45
100	266	385560	66.2	2.50
120	308.6	469280	75.9	3.09

Table 4.8: Metrics obtained using Objective 4 (14 – node topology)

No. of Demands	No. of hops	Path length (km)	Energy consumption (kWh)	Dollar cost (\$)
40	103	173060	38	0.63
80	224.8	377340	68.04	1.35
100	294.4	489910	71.36	1.62
120	356.8	580260	81.88	1.90

Tables 4.6 - 4.8 show the values corresponding to the different metrics obtained using Objective 2, Objective 3 and Objective 4 respectively. These tables follow the same pattern as Table 4.5 and show a standard growth in all metric values with an increase in the demand size.

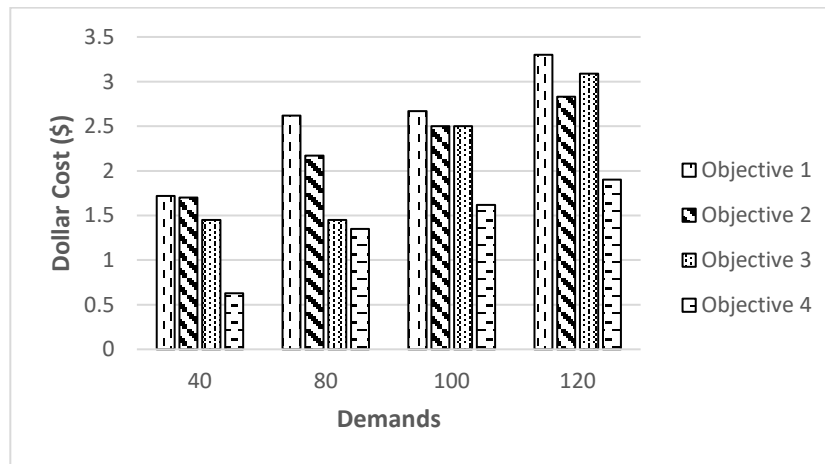

Figure 4.5: Cost Values obtained using different Objectives for different traffic loads (14-Node)

A comparison of dollar costs for routing different demands over the 14-node topology, using different objective functions, is shown in Figures 4.5. The number of demands is depicted on x-axis and dollar costs on y-axis. A standard growth in the dollar cost values is observed with an increase in the demand size. As expected, Objective 4, which directly minimizes dollar cost, performs better than the other objective functions. The improvement ranges from 6.8% - 56.5% over the next best performing value, which is obtained using Objective 3 (minimize energy consumption) for all traffic loads.

4.2.3 Comparison of prices for Objective 4 (real time vs. flat rate prices)

In this section, the overall electricity costs obtained using Objective 4 are compared for different electricity pricing models. Real time pricing model and flat rate pricing model are the models that have been used for comparison. Table 4.9 shows the results of the simulations performed on different topologies for 40 demands. Table 4.10 contains the values obtained by running simulations for the 14 – node topology for different demands. From the Tables 4.9 and 4.10, we can say that real time pricing model is better than the flat rate pricing model because it results in lower costs than the flat rate pricing model. This happens because real time pricing model has different prices for electricity usage every hour of the day while for the flat rate pricing model it is the same throughout the day. Hence, we can conclude that by using the real time pricing model we can save on the dollar costs for electricity.

Table 4.9: Values for Objective 4 with Real time and Flat rate prices for 40 demands

Nodes	Obj. 4 – Real Time (\$)	Obj. 4 – Flat Rate (\$)
11	0.83	1.86
14	0.61	1.66
24	1.37	3.64

Table 4.10: Values for Objective 4 with Real time and Flat rate prices for 14-node

No. of Demands	Obj. 4 – Real Time (\$)	Obj. 4 – Flat Rate (\$)
40	0.63	1.66
80	1.35	2.72
100	1.62	3.30
120	1.96	3.82

4.2.4 Comparison with different replicas

In this section, total electricity costs are compared for a different number of datacenter nodes (DCNs) to see how the number of replicas affects the results. Table 4.11 contains the value for Objective 4 with 2, 3 and 4 DCNs in the 14–node topology. From this table, we can see that using more replicas or datacenter nodes leads to better results.

Table 4.11: Overall electricity cost with different number of DCNs (14 - node)

No. of Demands	Dollar cost (\$) (2 replicas)	Dollar cost (\$) (3 replicas)	Dollar cost (\$) (4 replicas)
40	0.90	0.83	0.63
80	1.5	1.4	1.3
100	1.8	1.7	1.6
120	2.6	2.1	1.9

Figure 4.6 compares the total electricity costs with a varying number of DCNs for the 14-node topology under different traffic loads. The x-axis represents the number of demands (40, 80, 100 and 120) and the y-axis shows the dollar cost values. From the graph, we see that as the number of DCNs increase the dollar cost value decreases. This is because with more DCNs, it is possible to reach a destination node with fewer hops and there is a higher chance of finding a route using low-cost nodes.

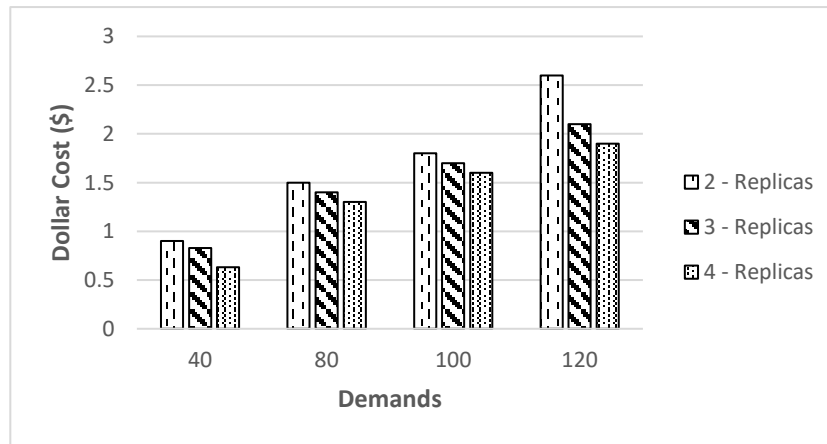

Figure 4.6: Dollar Cost Values with different replicas for different demands (14 - Node)

4.2.5 Comparison with different channels

In this section, total electricity costs are compared for a different number of channels to see how the number of channels affects the results. Table 4.12 contains the value for Objective 4 with 4, 8 and 16 channels in the 11–node topology. From this table, we can observe that using 16 channels has same or better results than the results obtained by using 4 channels or 8 channels.

Table 4.12: Overall electricity cost with 16, 8 and 4 channels (11 - node)

No. of Demands	Dollar cost (\$) (16 ch.)	Dollar cost (\$) (8 ch.)	Dollar cost (\$) (4 ch.)
40	0.83	0.85	0.87
80	1.39	1.42	1.55
100	1.69	1.72	1.76
120	1.91	1.93	1.95

CHAPTER – 5

CONCLUSION AND FUTURE WORK

5.1 Conclusion

In this thesis, we have proposed an ILP for the energy aware RWA for the fixed window scheduled traffic model. We have considered the anycast routing scheme to select the best option for the destination node and the real-time pricing model to select routes for the lightpaths. The main objective of this model is to reduce the overall electricity cost of a data center network by reducing the actual power consumption for all requested lightpath demands on the network. This model provides an appropriate route and an available wavelength for the lightpaths established over a specified time period. Our model selects the route and destination for each demand in such a way that that the total electricity cost for routing the set of demands is minimized. As outlined in Chapter 3, alternate objective functions to minimize the hops, distance and energy consumption are also considered. We have compared the electricity costs obtained by our alternative objective functions with our main objective function.

To test the performance of the proposed ILP, four different objective functions are presented for the same set of constraints. We have used different standard network topologies like NSFNET and COST-239, to conduct our simulations. We did simulations for our main objective function by using different number of replicas, different number of channels for different demands and topologies. Our main objective function (Objective 4), which minimizes the electricity cost, has the lowest dollar cost for all cases compared to other objective functions. Objective 4 may also increase the total energy consumption. This

means that when minimizing Objective 4, the requests may use longer routes and paths that lead to higher energy consumption if the *cost* of energy for those links/nodes is significantly lower. We also compared it with the flat rate pricing model. Our experimental results show that the proposed ILP which uses the real time pricing model has better results in terms of costs than the flat rate pricing model.

5.2 Future work

“Directed attacks or natural disasters pose a serious threat to the safety of user data which are in the data centers, hence disaster survivability in communication networks is a major challenge [2]”. Due to various faults, there can be channel failure, link failure or node failure. The proposed ILP does not address the problem of survivability against disasters. Fault management in optical network is performed through storing backup resources in advance called protection [43]. Protection of paths against failures can be attained by providing a backup path to the same destination, such that this backup path should be link-disjoint to the primary path [43]. Protection schemes like dedicated path protection (DPP), shared path protection (SPP), dedicated link protection and shared link protection can be incorporated to obtain a fully secure and robust RWA for the proposed ILP [44] [45].

The proposed ILP uses fixed window scheduled traffic demand allocation model. In this model, the starting time and holding time for each demand is known in advance. “In sliding scheduled traffic demand model instead of starting and end time for demand, a larger window is specified for each demand, during which the demand must be serviced [39]”. In sliding window model, each demand is assigned a suitable starting time. Hence

there is more flexibility with time in sliding window model. Hence using this model for our ILP may lead to greater savings regarding cost and energy.

REFERENCES/BIBLIOGRAPHY

- [1] Deylamsalehi, A., Afsharlar, P., & Vokkarane, V. M. (2016, February). Real-time energy price-aware anycast RWA in optical data center networks. In *Computing, Networking and Communications (ICNC), 2016 International Conference on* (pp. 1-6). IEEE.
- [2] Das, Ruchisree, "Dynamic Provisioning of Fault Tolerant Optical Networks for Data Centers" (2016). *Electronic Theses and Dissertations*. 5808.
- [3] Jiang, H. P., Chuck, D., & Chen, W. M. (2016). Energy-aware data center networks. *Journal of Network and Computer Applications*, 68, 80-89.
- [4] M. Mills, "The cloud begins with coal: Big data, big networks, big infrastructure, and big power," An Overview of the Electricity Used by the Global Digital Ecosystem. National Mining Association and American Coalition for Clean Coal Electricity, 2013.
- [5] P. Agarwal, A. Efrat, S. Ganjugunte, D. Hay, S. Sankararaman, and G. Zussman, "The Resilience of WDM Networks to Probabilistic Geographical Failures," in Proc. IEEE INFOCOM, Shanghai, China, Apr. 2011, pp. 1521–1529.
- [6] Jun Zheng & Hussein T. Mouftah, "Optical WDM networks, concepts and Design," IEEE press, John Wiley –Sons, Inc, Publication, vol. 3, no. 4, pp.1-4, April 2013.
- [7] H. Zang, J. P. Jue, and B. Mukherjee. A review of routing and wavelength assignment approaches for wavelength-routed optical WDM networks. *Optical Networks*, 1(1):47–60, January 2000.

- [8] Bandyopadhyay, S. (2007). *Dissemination of Information in Optical Networks: From Technology to Algorithms*. Springer Science & Business Media
- [9] Stevens, T., De Leenheer, M., Develder, C., De Turck, F., Dhoedt, B., & Demeester, P. (2006, September). Anycast routing algorithms for effective job scheduling in optical grids. In *Optical Communications, 2006. ECOC 2006. European Conference on* (pp. 1-2). IEEE
- [10] Singh, S., Chana, I., Singh, M., & Buyya, R. (2016). SOCCER: Self-Optimization of Energy-efficient Cloud Resources. *Cluster Computing*, 19(4), 1787-1800
- [11] Moore, B. (2002). Taking the data center: Power and cooling challenge. *Energy User News*, 27(9), 20.
- [12] Dong, X., El-Gorashi, T., & Elmirghani, J. M. (2011). Green IP over WDM networks with data centers. *Journal of Lightwave Technology*, 29(12), 1861-1880.
- [13] A. Qureshi, "Power-demand routing in massive geo-distributed systems," Ph.D. dissertation, Massachusetts Institute of Technology, 2010.
- [14] <https://www.techopedia.com/definition/23643/optical-network>
- [15] <http://computer.howstuffworks.com/fiber-optic6.htm>
- [16] S. Ferdousi, F. Dikbiyik, M. F. Habib, M. Tornatore, and B. Mukherjee, "Disaster-aware data center placement and Dynamic content management in cloud networks," *Journal of Optical Communications and Networking*, vol. 7, no. 7, pp. 681–694, 2015.

- [17] Ishio, Hideki, Junichiro Minowa, and Kiyoshi Nosu. "Review and status of wavelength-division-multiplexing technology and its application." *Journal of Lightwave Technology* 2.4 (1984): 448-463.
- [18] Ozdaglar, A. E., & Bertsekas, D. P. (2003). Routing and wavelength assignment in optical networks. *IEEE/ACM Transactions On Networking* (ton), 11(2), 259-272.
- [19] Jaekel, A., & Chen, Y. (2006). Efficient Distributed Algorithm for RWA Using Path Protection. *JNW*, 1(3), 1-8.
- [20] Chen, Y., & Jaekel, A. (2013, June). Energy optimization in optical grids through anycasting. In *Communications (ICC), 2013 IEEE International Conference on* (pp. 3835-3839). IEEE.
- [21] Deylamsalehi, A., Afsharlar, P., & Vokkarane, V. M. (2016, September). Modeling energy costs and emissions for anycast RWA in optical data center networks. In *Sarnoff Symposium, 2016 IEEE 37th* (pp. 7-12). IEEE.]
- [22] Chen, Y., & Jaekel, A. (2013). Energy-aware scheduling and resource allocation for periodic traffic demands. *Journal of Optical Communications and Networking*, 5(4), 261-270.
- [23] Chen Y., Jaekel A., & Li K. (2014, June). Energy efficient anycast routing for scheduled lightpath demands in optical grids. In *Communications (QBSC), 2014 27th Biennial Symposium on* (pp. 10-13). IEEE
- [24] <https://www.paloaltonetworks.com/cyberpedia/what-is-a-data-center>

- [25] El-Serafy, M. A., Aly, M. H., El-Badawy, E. S. A., & Ghaleb, I. A. A Comparison between Two Post-Failure Load Distribution Techniques with Multiple Routing Configurations.
- [26] Henriques de Gusmão, A. P., & Pereira Medeiros, C. (2016). A Model for Selecting a Strategic Information System Using the FITradeoff. *Mathematical Problems in Engineering*, 2016.
- [27] Cimini, G., Squartini, T., Garlaschelli, D., & Gabrielli, A. (2014). Systemic risk analysis in reconstructed economic and financial networks. arXiv preprint arXiv:1411.7613.
- [28] Naas, N., & Mouftah, H. (2016, June). Power-aware design of the optical interconnect for future data centers. In *Computers and Communication (ISCC), 2016 IEEE Symposium on* (pp. 675-682). IEEE.
- [29] Wu, J., Zhang, J. Y., & Savoie, M. (2013). Lightpath scheduling and routing for green data centres. *Telecommunication Systems*, 1-14.
- [30] Wu, Y., Chiaraviglio, L., Mellia, M., & Neri, F. (2009, September). Power-aware routing and wavelength assignment in optical networks. In *Optical Communication, 2009. ECOC'09. 35th European Conference on* (pp. 1-2). IEEE.
- [31] Rauen, Z. I., Kantarci, B., & Mouftah, H. T. (2017). Resiliency versus energy sustainability in optical inter-datacenter networks. *Optical Switching and Networking*, 23, 144-155.

- [32] Lemay, M., Nguyen, K., Arnaud, B. S., & Cheriet, M. (2011). Convergence of cloud computing and network virtualization: Towards a zero-carbon network. *IEEE Internet Computing Magazine*, 16(6), 51-59.
- [33] Buysse J., Cavdar C., De Leenheer M., Dhoedt B., & Develder C. (2011, November). Improving energy efficiency in optical cloud networks by exploiting anycast routing. In *Asia Communications and Photonics Conference and Exhibition* (p. 83100X). Optical Society of America.
- [34] <http://www.kitz.co.uk/adsl/fibre-optic-cables.htm> [retrieved on date:22-march-2017]
- [35] <https://www.quora.com/Why-do-fiber-optics-use-total-internal-reflection-instead-of-specular-reflection> [retrieved on date:22-march-2017]
- [36] <http://www.edgefx.in/wp-content/uploads/2014/04/34.jpg> [retrieved on date:22-march-2017]
- [37] <https://en.wikipedia.org/wiki/Multicast> [retrieved on date:23-march-2017]
- [38] <http://www.archdaily.com/285237/facebook-prineville-data-center-sheehanpartners-508625-f328ba0d55b2000090-facebook-prineville-data-center-sheehan-partners-photo> [retrieved on date:23-march-2017]
- [39] Rami, Darshil, "Energy Efficient Anycast Routing for Sliding Scheduled Lightpath Demands in Optical Grids" (2016). *Electronic Theses and Dissertations*. 5662.
- [40] U.S. Environmental Protection Agency's Data Center Report to Congress. <http://tinyurl.com/2jz3ft>

- [41] A. Coiro, M. Listanti, A. Valenti and F. Matera, "Power-Aware Routing and Wavelength Assignment in Multi-Fiber Optical Networks," *Journal of Optical Communication and Networking*, 3 (11) (2011) 816 - 829.
- [42] F. Musumeci, M. Tornatore and A. Pattavina, "A Power Consumption Analysis for IP-Over-WDM Core Network Architectures," *Journal of Optical Communication and Networking*, 4 (2) (2012) 108 - 117.
- [43] Saini, Himanshi, and Amit Kumar Garg. "Protection and restoration schemes in optical networks: a comprehensive survey." *International Journal of Microwaves Applications* 2.1 (2013).
- [44] Aneja, Y. Jaekel, A., Bandyopadhyay, S. 2007. Some studies on path Protection in WDM networks. *Photonic Net. Com.*, 2007.
- [45] Hashimoto, M. and Miura, K., 2012. Layer-Wise Topology Design for Cost Effective IP Optical Networks.
- [46] AMPL, I. CPLEX software. *ILOG website: www.ilog.com/products/cplex.*

VITA AUCTORIS

NAME: Karan Neginhal

PLACE OF BIRTH: Vadodara, India

YEAR OF BIRTH: 1992

EDUCATION: Sabari Vidyalaya, Vadodara, India, 2011

Gujarat Technological University, India, 2015

University of Windsor, M.Sc., Windsor, ON,
2017